

Flash

3V Only 32 Mbit Serial Flash Memory with Dual

■ FEATURES

- Single supply voltage 2.7~3.6V
- Standard and Dual SPI
- Speed
 - Read max frequency: 33MHz
 - Fast Read max frequency: 50MHz / 86MHz / 100MHz
 - Fast Read Dual max frequency: 50MHz / 86MHz / 100MHz (100MHz / 172MHz / 200MHz equivalent Dual SPI)
- Low power consumption
 - Active current: 35 mA
 - Standby current: 30 μ A
 - Deep Power Down current: 5 μ A
- Reliability
 - 100,000 typical program/erase cycles
 - 20 years Data Retention
- Program
 - Byte programming time: 7 μ s (typical)
 - Page programming time: 1.5 ms (typical)
- Erase
 - Chip erase time 25 sec (typical)
 - Block erase time 1 sec (typical)
 - Sector erase time 90 ms (typical)
- Page Programming
 - 256 byte per programmable page
- Lockable 512 bytes OTP security sector
- SPI Serial Interface
 - SPI Compatible: Mode 0 and Mode 3
- End of program or erase detection
- Write Protect (\overline{WP})
- Hold Pin (\overline{HOLD})
- All Pb-free products are RoHS-Compliant

■ ORDERING INFORMATION

Product ID	Speed	Package		Comments
F25L32PA –50PAG	50MHz	8 lead SOIC	200mil	Pb-free
F25L32PA –86PAG	86MHz	8 lead SOIC	200mil	Pb-free
F25L32PA –100PAG	100MHz	8 lead SOIC	200mil	Pb-free
F25L32PA –50PHG	50MHz	16 lead SOIC	300mil	Pb-free
F25L32PA –86PHG	86MHz	16 lead SOIC	300mil	Pb-free
F25L32PA –100PHG	100MHz	16 lead SOIC	300mil	Pb-free

■ GENERAL DESCRIPTION

The F25L32PA is a 32Megabit, 3V only CMOS Serial Flash memory device. The device supports the standard and Dual Serial Peripheral Interface (SPI). ESMT's memory devices reliably store memory data even after 100,000 programming and erase cycles.

The memory array can be organized into 16,384 programmable pages of 256 byte each. 1 to 256 byte can be programmed at a time with the Page Program instruction.

The device features sector erase architecture. The memory array

is divided into 1024 uniform sectors with 4K byte each; 64 uniform blocks with 64K byte each. Sectors can be erased individually without affecting the data in other sectors. Blocks can be erased individually without affecting the data in other blocks. Whole chip erase capabilities provide the flexibility to revise the data in the device. The device has Sector, Block or Chip Erase but no page erase.

The sector protect/unprotect feature disables both program and erase operations in any combination of the sectors of the memory.

■ PIN CONFIGURATIONS

8-Lead SOIC

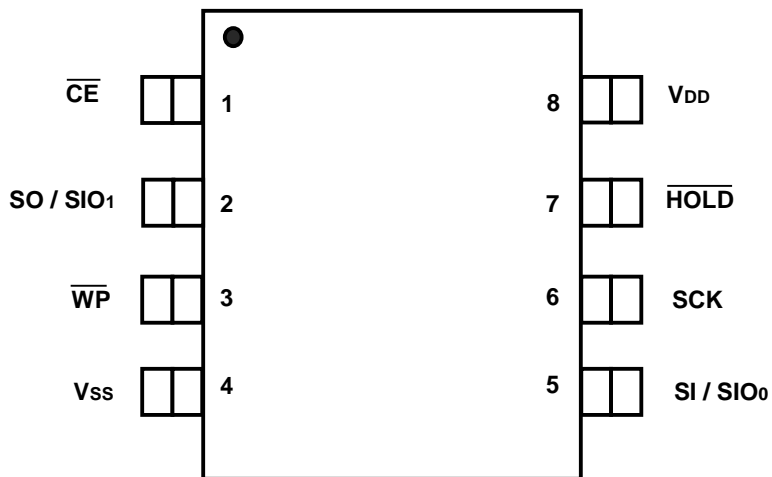

16-Lead SOIC

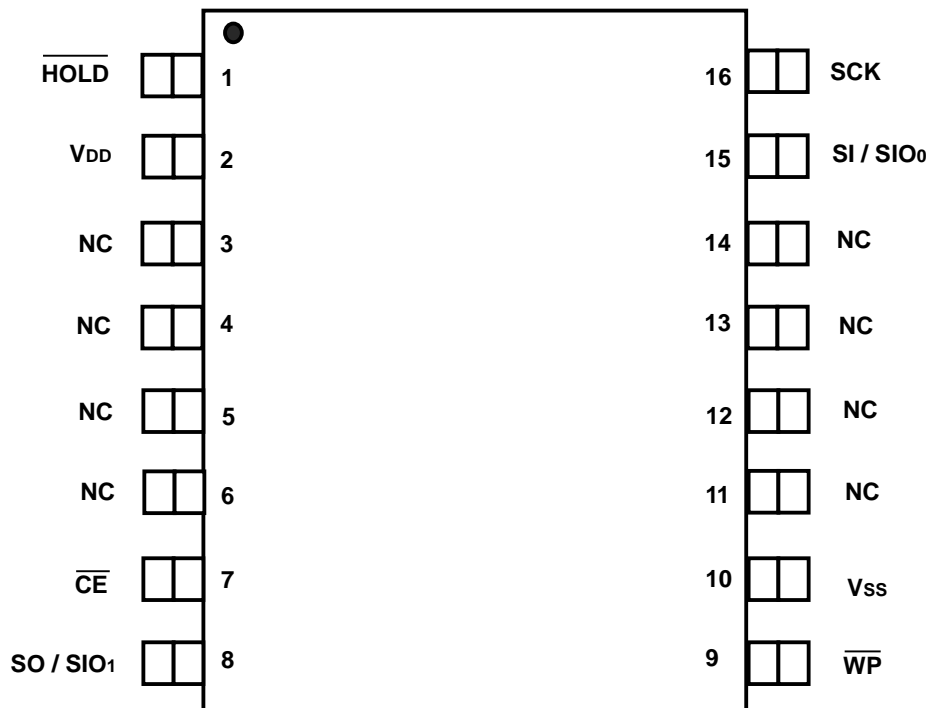

■ PIN DESCRIPTION

Symbol	Pin Name	Functions
SCK	Serial Clock	To provide the timing for serial input and output operations
SI / SIO ₀	Serial Data Input / Serial Data Input Output 0	To transfer commands, addresses or data serially into the device. Data is latched on the rising edge of SCK (for Standard mode). / Bidirectional IO pin to transfer commands, addresses or data serially into the device on the rising edge of SCK and read data or status from the device on the falling edge of SCK(for Dual mode).
SO / SIO ₁	Serial Data Output / Serial Data Input Output 1	To transfer data serially out of the device. Data is shifted out on the falling edge of SCK (for Standard mode). / Bidirectional IO pin to transfer commands, addresses or data serially into the device on the rising edge of SCK and read data or status from the device on the falling edge of SCK (for Dual mode).
$\overline{\text{CE}}$	Chip Enable	To activate the device when $\overline{\text{CE}}$ is low.
$\overline{\text{WP}}$	Write Protect	The Write Protect ($\overline{\text{WP}}$) pin is used to enable/disable BPL bit in the status register.
$\overline{\text{HOLD}}$	Hold	To temporality stop serial communication with SPI flash memory without resetting the device.
V _{DD}	Power Supply	To provide power.
V _{SS}	Ground	

■ FUNCTIONAL BLOCK DIAGRAM

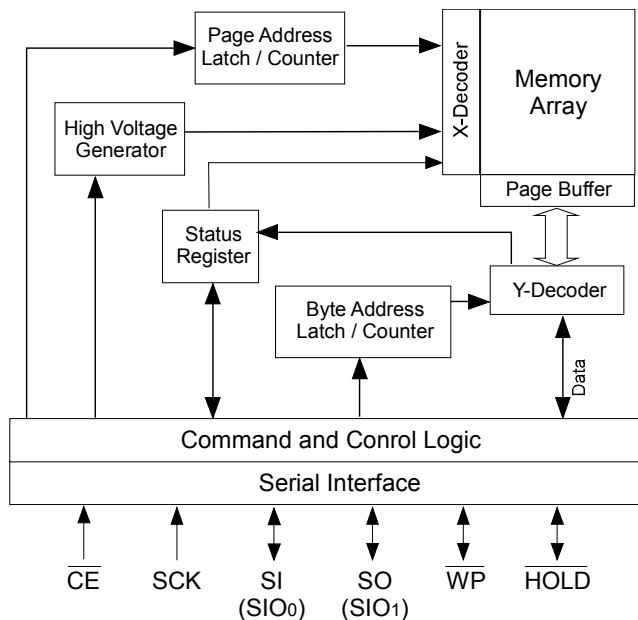

■ SECTOR STRUCTURE

Table 1: F25L32PA Sector Address Table

Block	Sector	Sector Size (Kbytes)	Address range	Block Address					
				A21	A20	A19	A18	A17	A16
63	1023	4KB	3FF000H – 3FFFFFFH	1	1	1	1	1	1
	:	:	:						
62	1008	4KB	3F0000H – 3F0FFFH	1	1	1	1	1	0
	:	:	:						
61	1007	4KB	3EF000H – 3EFFFFFFH	1	1	1	1	0	1
	:	:	:						
60	992	4KB	3E0000H – 3E0FFFH	1	1	1	1	0	0
	:	:	:						
59	991	4KB	3DF000H – 3DFFFFFFH	1	1	1	1	0	1
	:	:	:						
58	976	4KB	3D0000H – 3D0FFFH	1	1	1	0	1	0
	:	:	:						
57	975	4KB	3CF000H – 3CFFFFFFH	1	1	1	1	0	0
	:	:	:						
56	960	4KB	3C0000H – 3C0FFFH	1	1	1	0	1	1
	:	:	:						
55	959	4KB	3BF000H – 3BFFFFFFH	1	1	1	0	1	1
	:	:	:						
54	944	4KB	3B0000H – 3B0FFFH	1	1	1	0	1	0
	:	:	:						
53	943	4KB	3AF000H – 3AFFFFFFH	1	1	1	0	0	1
	:	:	:						
52	928	4KB	3A0000H – 3A0FFFH	1	1	1	0	0	0
	:	:	:						
51	927	4KB	39F000H – 39FFFFFFH	1	1	1	0	0	1
	:	:	:						
50	912	4KB	390000H – 390FFFH	1	1	1	0	0	0
	:	:	:						
49	911	4KB	38F000H – 38FFFFFFH	1	1	0	1	1	1
	:	:	:						
48	896	4KB	380000H – 380FFFH	1	1	0	1	1	1
	:	:	:						
47	895	4KB	37F000H – 37FFFFFFH	1	1	0	1	1	0
	:	:	:						
46	880	4KB	370000H – 370FFFH	1	1	0	1	1	0
	:	:	:						
45	879	4KB	36F000H – 36FFFFFFH	1	1	0	1	0	1
	:	:	:						
44	864	4KB	360000H – 360FFFH	1	1	0	1	0	0
	:	:	:						
43	863	4KB	35F000H – 35FFFFFFH	1	1	0	1	0	1
	:	:	:						
42	848	4KB	350000H – 350FFFH	1	1	0	1	0	0
	:	:	:						
41	847	4KB	34F000H – 34FFFFFFH	1	1	0	1	0	0
	:	:	:						
40	830	4KB	340000H – 340FFFH	1	1	0	0	1	1
	:	:	:						
39	831	4KB	33F000H – 33FFFFFFH	1	1	0	0	1	1
	:	:	:						
38	816	4KB	330000H – 330FFFH	1	1	0	0	1	1
	:	:	:						

Table 1: F25L32PA Sector Address Table – Continued I

Block	Sector	Sector Size (Kbytes)	Address range	Block Address					
				A21	A20	A19	A18	A17	A16
50	815	4KB	32F000H – 32FFFFH	1	1	0	0	1	0
	:	:	:						
49	800	4KB	320000H – 320FFFH	1	1	0	0	0	1
	799	4KB	31F000H – 31FFFFH						
48	784	4KB	310000H – 310FFFH	1	1	0	0	0	0
	783	4KB	30F000H – 30FFFFH						
47	768	4KB	300000H – 300FFFH	1	0	1	1	1	1
	767	4KB	2FF000H – 2FFFFFH						
46	752	4KB	2F0000H – 2F0FFFH	1	0	1	1	1	0
	751	4KB	2EF000H – 2EFFFFH						
45	736	4KB	2E0000H – 2E0FFFH	1	0	1	1	0	1
	735	4KB	2DF000H – 2DFFFFH						
44	720	4KB	2D0000H – 2D0FFFH	1	0	1	1	0	0
	719	4KB	2CF000H – 2CFFFFH						
43	704	4KB	2C0000H – 2C0FFFH	1	0	1	0	1	1
	703	4KB	2BF000H – 2BFFFFH						
42	688	4KB	2B0000H – 2B0FFFH	1	0	1	0	1	0
	687	4KB	2AF000H – 2AFFFFH						
41	672	4KB	2A0000H – 2A0FFFH	1	0	1	0	0	1
	671	4KB	29F000H – 29FFFFH						
40	656	4KB	290000H – 290FFFH	1	0	1	0	0	0
	655	4KB	28F000H – 28FFFFH						
39	640	4KB	280000H – 280FFFH	1	0	0	1	1	1
	639	4KB	27F000H – 27FFFFH						
38	624	4KB	270000H – 270FFFH	1	0	0	1	1	0
	623	4KB	26F000H – 26FFFFH						
	608	4KB	260000H – 260FFFH						

Table 1: F25L32PA Sector Address Table – Continued II

Block	Sector	Sector Size (Kbytes)	Address range	Block Address					
				A21	A20	A19	A18	A17	A16
37	607	4KB	25F000H – 25FFFFH	1	0	0	1	0	1
	:	:	:						
36	592	4KB	250000H – 250FFFH	1	0	0	1	0	0
	591	4KB	24F000H – 24FFFFH						
35	576	4KB	240000H – 240FFFH	1	0	0	0	1	1
	575	4KB	23F000H – 23FFFFH						
34	560	4KB	230000H – 230FFFH	1	0	0	0	1	0
	559	4KB	22F000H – 22FFFFH						
33	544	4KB	220000H – 220FFFH	1	0	0	0	0	1
	543	4KB	21F000H – 21FFFFH						
32	528	4KB	210000H – 210FFFH	1	0	0	0	0	0
	527	4KB	20F000H – 20FFFFH						
31	512	4KB	200000H – 200FFFH	0	1	1	1	1	1
	511	4KB	1FF000H – 1FFFFFH						
30	496	4KB	1F0000H – 1F0FFFH	0	1	1	1	1	0
	495	4KB	1EF000H – 1EFFFFH						
29	480	4KB	1E0000H – 1E0FFFH	0	1	1	1	0	1
	479	4KB	1DF000H – 1DFFFFH						
28	464	4KB	1D0000H – 1D0FFFH	0	1	1	1	0	0
	463	4KB	1CF000H – 1CFFFFH						
27	448	4KB	1C0000H – 1C0FFFH	0	1	1	0	1	1
	447	4KB	1BF000H – 1BFFFFH						
26	432	4KB	1B0000H – 1B0FFFH	0	1	1	0	1	0
	431	4KB	1AF000H – 1AFFFFH						
25	416	4KB	1A0000H – 1A0FFFH	0	1	1	0	0	1
	415	4KB	19F000H – 19FFFFH						
	400	4KB	190000H – 190FFFH						

Table 1: F25L32PA Sector Address Table – Continued III

Block	Sector	Sector Size (Kbytes)	Address range	Block Address					
				A21	A20	A19	A18	A17	A16
24	399	4KB	18F000H – 18FFFFH	0	1	1	0	0	0
	:	:	:						
23	384	4KB	180000H – 180FFFH	0	1	0	1	1	1
	383	4KB	17F000H – 17FFFFH						
22	368	4KB	170000H – 170FFFH	0	1	0	1	1	0
	367	4KB	16F000H – 16FFFFH						
21	352	4KB	160000H – 160FFFH	0	1	0	1	0	1
	351	4KB	15F000H – 15FFFFH						
20	336	4KB	150000H – 150FFFH	0	1	0	1	0	0
	335	4KB	14F000H – 14FFFFH						
19	320	4KB	140000H – 140FFFH	0	1	0	0	1	1
	319	4KB	13F000H – 13FFFFH						
18	304	4KB	130000H – 130FFFH	0	1	0	0	1	0
	303	4KB	12F000H – 12FFFFH						
17	288	4KB	120000H – 120FFFH	0	1	0	0	0	1
	287	4KB	11F000H – 11FFFFH						
16	272	4KB	110000H – 110FFFH	0	1	0	0	0	0
	271	4KB	10F000H – 10FFFFH						
15	256	4KB	100000H – 100FFFH	0	0	1	1	1	1
	255	4KB	0FF000H – 0FFFFFH						
14	240	4KB	0F0000H – 0F0FFFH	0	0	1	1	1	0
	239	4KB	0EF000H – 0EFFFFH						
13	224	4KB	0E0000H – 0E0FFFH	0	0	1	1	0	1
	223	4KB	0DF000H – 0DFFFFH						
12	208	4KB	0D0000H – 0D0FFFH	0	0	1	1	0	0
	207	4KB	0CF000H – 0CFFFFH						
	192	4KB	0C0000H – 0C0FFFH						

Table 1: F25L32PA Sector Address Table – Continued IV

Block	Sector	Sector Size (Kbytes)	Address range	Block Address					
				A21	A20	A19	A18	A17	A16
11	191	4KB	0BF000H – 0BFFFFH	0	0	1	0	1	1
	:	:	:						
10	176	4KB	0B0000H – 0B0FFFH	0	0	1	0	1	0
	:	:	:						
9	175	4KB	0AF000H – 0AFFFFH	0	0	1	0	0	1
	:	:	:						
8	160	4KB	0A0000H – 0A0FFFH	0	0	1	0	0	0
	:	:	:						
7	159	4KB	09F000H – 09FFFFH	0	0	0	1	1	1
	:	:	:						
6	144	4KB	090000H – 090FFFH	0	0	0	1	1	0
	:	:	:						
5	143	4KB	08F000H – 08FFFFH	0	0	0	1	0	0
	:	:	:						
4	128	4KB	080000H – 080FFFH	0	0	0	1	0	0
	:	:	:						
3	127	4KB	07F000H – 07FFFFH	0	0	0	1	1	1
	:	:	:						
2	112	4KB	070000H – 070FFFH	0	0	0	1	1	0
	:	:	:						
1	111	4KB	06F000H – 06FFFFH	0	0	0	1	0	1
	:	:	:						
0	96	4KB	060000H – 060FFFH	0	0	0	1	0	1
	:	:	:						
0	95	4KB	05F000H – 05FFFFH	0	0	0	1	0	0
	:	:	:						
0	80	4KB	050000H – 050FFFH	0	0	0	1	0	0
	:	:	:						
0	79	4KB	04F000H – 04FFFFH	0	0	0	1	0	0
	:	:	:						
0	64	4KB	040000H – 040FFFH	0	0	0	0	1	1
	:	:	:						
0	63	4KB	03F000H – 03FFFFH	0	0	0	0	1	0
	:	:	:						
0	48	4KB	030000H – 030FFFH	0	0	0	0	1	0
	:	:	:						
0	47	4KB	02F000H – 02FFFFH	0	0	0	0	0	1
	:	:	:						
0	32	4KB	020000H – 020FFFH	0	0	0	0	0	1
	:	:	:						
0	31	4KB	01F000H – 01FFFFH	0	0	0	0	0	0
	:	:	:						
0	16	4KB	010000H – 010FFFH	0	0	0	0	0	0
	:	:	:						
0	15	4KB	00F000H – 00FFFFH	0	0	0	0	0	0
	:	:	:						
0	0	4KB	000000H – 000FFFH	0	0	0	0	0	0

■ STATUS REGISTER

The software status register provides status on whether the flash memory array is available for any Read or Write operation, whether the device is Write enabled, and the state of the memory Write protection. During an internal Erase or Program operation,

the status register may be read only to determine the completion of an operation in progress. Table 2 describes the function of each bit in the software status register.

Table 2: Software Status Register

Bit	Name	Function	Default at Power-up	Read/Write
Status Register				
0	BUSY	1 = Internal Write operation is in progress 0 = No internal Write operation is in progress	0	R
1	WEL	1 = Device is memory Write enabled 0 = Device is not memory Write enabled	0	R
2	BP0	Indicate current level of block write protection (See Table 3)	1	R/W
3	BP1	Indicate current level of block write protection (See Table 3)	1	R/W
4	BP2	Indicate current level of block write protection (See Table 3)	1	R/W
5	RESERVED	Reserved for future use	0	N/A
6	RESERVED	Reserved for future use	0	N/A
7	BPL	1 = BP2,BP1,BP0 are read-only bits 0 = BP2,BP1,BP0 are read/writable	0	R/W

Note:

1. Only BP0, BP1, BP2 and BPL are writable.
2. All register bits are volatility
3. All area are protected at power-on (BP2=BP1=BP0=1)

WRITE ENABLE LATCH (WEL)

The Write-Enable-Latch bit indicates the status of the internal memory Write Enable Latch. If this bit is set to “1”, it indicates the device is Write enabled. If the bit is set to “0” (reset), it indicates the device is not Write enabled and does not accept any memory Write (Program/ Erase) commands. This bit is automatically reset under the following conditions:

- Power-up
- Write Disable (WRDI) instruction completion
- Page Program instruction completion
- Sector Erase instruction completion
- Block Erase instruction completion
- Chip Erase instruction completion
- Write Status Register instructions

BUSY

The BUSY bit determines whether there is an internal Erase or Program operation in progress. A “1” for the BUSY bit indicates the device is busy with an operation in progress. A “0” indicates the device is ready for the next valid operation.

Table 3: F25L32PA Block Protection Table

TOP

Protection Level	Status Register Bit			Protected Memory Area	
	BP2	BP1	BP0	Block Range	Address Range
0	0	0	0	None	None
Upper 1/64	0	0	1	Block 63	3F0000H –3FFFFFFH
Upper 1/32	0	1	0	Block 62~63	3E0000H –3FFFFFFH
Upper 1/16	0	1	1	Block 60~63	3C0000H –3FFFFFFH
Upper 1/8	1	0	0	Block 56~63	380000H –3FFFFFFH
Upper 1/4	1	0	1	Block 48~63	300000H –3FFFFFFH
Upper 1/2	1	1	0	Block 32~63	200000H –3FFFFFFH
All Blocks	1	1	1	Block 0~63	000000H –3FFFFFFH

Block Protection (BP2, BP1, BP0)

The Block-Protection (BP2, BP1, BP0) bits define the size of the memory area, as defined in Table 3, to be software protected against any memory Write (Program or Erase) operations. The Write Status Register (WRSR) instruction is used to program the BP2, BP1, BP0 bits as long as \overline{WP} is high or the Block-Protection-Look (BPL) bit is 0. Chip Erase can only be executed if Block-Protection bits are all 0. After power-up, BP2, BP1 and BP0 are set to 1.

Block Protection Lock-Down (BPL)

\overline{WP} pin driven low (V_{IL}), enables the Block-Protection-Lock-Down (BPL) bit. When BPL is set to 1, it prevents any further alteration of the BPL, BP2, BP1, and BP0 bits. When the \overline{WP} pin is driven high (V_{IH}), the BPL bit has no effect and its value is "Don't Care". After power-up, the BPL bit is reset to 0.

■ HOLD OPERATION

$\overline{\text{HOLD}}$ pin is used to pause a serial sequence underway with the SPI flash memory without resetting the clocking sequence. To activate the $\overline{\text{HOLD}}$ mode, $\overline{\text{CE}}$ must be in active low state. The $\overline{\text{HOLD}}$ mode begins when the $\overline{\text{SCK}}$ active low state coincides with the falling edge of the $\overline{\text{HOLD}}$ signal. The HOLD mode ends when the $\overline{\text{HOLD}}$ signal's rising edge coincides with the $\overline{\text{SCK}}$ active low state.

If the falling edge of the $\overline{\text{HOLD}}$ signal does not coincide with the $\overline{\text{SCK}}$ active low state, then the device enters Hold mode when the $\overline{\text{SCK}}$ next reaches the active low state.

Similarly, if the rising edge of the $\overline{\text{HOLD}}$ signal does not coincide with the $\overline{\text{SCK}}$ active low state, then the device exits in Hold mode when the $\overline{\text{SCK}}$ next reaches the active low state. See Figure 1 for Hold Condition waveform.

Once the device enters Hold mode, SO will be in high impedance state while SI and SCK can be V_{IL} or V_{IH} .

If $\overline{\text{CE}}$ is driven active high during a Hold condition, it resets the internal logic of the device. As long as $\overline{\text{HOLD}}$ signal is low, the memory remains in the Hold condition. To resume communication with the device, $\overline{\text{HOLD}}$ must be driven active high, and $\overline{\text{CE}}$ must be driven active low. See Figure 23 for Hold timing.

The $\overline{\text{HOLD}}$ function is only available for Standard and Dual SPI operation.

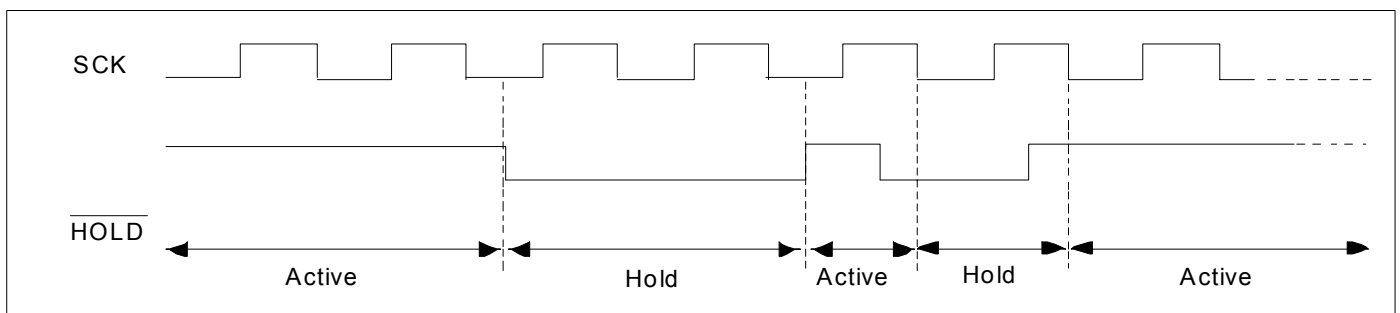

Figure 1: HOLD Condition Waveform

■ WRITE PROTECTION

The device provides software Write Protection. The Write-Protect pin ($\overline{\text{WP}}$) enables or disables the lock-down function of the status register. The Block-Protection bits (BP2, BP1, BP0, and BPL) in the status register provide Write protection to the memory array and the status register. See Table 3 for Block-Protection description.

Write Protect Pin ($\overline{\text{WP}}$)

The Write-Protect ($\overline{\text{WP}}$) pin enables the lock-down function of the BPL bit (bit 7) in the status register. When $\overline{\text{WP}}$ is driven low, the execution of the Write Status Register (WRSR) instruction is determined by the value of the BPL bit (see Table 4). When $\overline{\text{WP}}$ is high, the lock-down function of the BPL bit is disabled.

Table 4: Conditions to Execute Write-Status- Register (WRSR) Instruction

$\overline{\text{WP}}$	BPL	Execute WRSR Instruction
L	1	Not Allowed
L	0	Allowed
H	X	Allowed

■ INSTRUCTIONS

Instructions are used to Read, Write (Erase and Program), and configure the device. The instruction bus cycles are 8 bits each for commands (Op Code), data, and addresses. Prior to executing any Page Program, Write Status Register, Sector Erase, Block Erase, or Chip Erase instructions, the Write Enable (WREN) instruction must be executed first. The complete list of the instructions is provided in Table 5. All instructions are synchronized off a high to low transition of \overline{CE} . Inputs will be accepted on the rising edge of SCK starting with the most significant bit. \overline{CE} must be driven low before an instruction is

entered and must be driven high after the last bit of the instruction has been shifted in (except for Read, Read ID, Read Status Register, Read Electronic Signature instructions). Any low to high transition on \overline{CE} , before receiving the last bit of an instruction bus cycle, will terminate the instruction in progress and return the device to the standby mode.

Instruction commands (Op Code), addresses, and data are all input from the most significant bit (MSB) first.

Table 5: Device Operation Instruction

Operation	Max. Freq	Bus Cycle ¹⁻³													
		1		2		3		4		5		6		N	
		S _{IN}	S _{OUT}	S _{IN}	S _{OUT}	S _{IN}	S _{OUT}	S _{IN}	S _{OUT}	S _{IN}	S _{OUT}	S _{IN}	S _{OUT}	S _{IN}	S _{OUT}
Read	33 MHz	03H	Hi-Z	A ₂₃ -A ₁₆	Hi-Z	A ₁₅ -A ₈	Hi-Z	A ₇ -A ₀	Hi-Z	X	D _{OUT0}	X	D _{OUT1}	X	cont.
Fast Read	50MHz ~ 100MHz	0BH	Hi-Z	A ₂₃ -A ₁₆	Hi-Z	A ₁₅ -A ₈	Hi-Z	A ₇ -A ₀	Hi-Z	X	X	X	D _{OUT0}	X	cont.
Fast Read Dual Output ^{12,13}		3BH		A ₂₃ -A ₁₆		A ₁₅ -A ₈		A ₇ -A ₀		X		D _{OUT0-1}			cont.
Fast Read Dual I/O ^{12,14}		BBH		A ₂₃ -A ₈		A ₇ -A ₀ , M ₇ -M ₀		D _{OUT0-1}		cont.		-		-	-
Sector Erase ⁴ (4K Byte)		20H	Hi-Z	A ₂₃ -A ₁₆	Hi-Z	A ₁₅ -A ₈	Hi-Z	A ₇ -A ₀	Hi-Z	-	-	-	-	-	-
Block Erase ⁴ (64K Byte)		D8H	Hi-Z	A ₂₃ -A ₁₆	Hi-Z	A ₁₅ -A ₈	Hi-Z	A ₇ -A ₀	Hi-Z	-	-	-	-	-	-
Chip Erase		60H / C7H	Hi-Z	-	-	-	-	-	-	-	-	-	-	-	-
Page Program (PP)		02H	Hi-Z	A ₂₃ -A ₁₆	Hi-Z	A ₁₅ -A ₈	Hi-Z	A ₇ -A ₀	Hi-Z	D _{IN0}	Hi-Z	D _{IN1}	Hi-Z	Up to 256 bytes	Hi-Z
Mode Bit Reset ¹⁵		FFH	Hi-Z	FFH	Hi-Z	-	-	-	-	-	-	-	-	-	-
Deep Power Down (DP)		B9h	Hi-Z	-	-	-	-	-	-	-	-	-	-	-	-
Read Status Register (RDSR) ⁶		05H	Hi-Z	X	D _{OUT} (S ₇ -S ₀)	-	-	-	-	-	-	-	-	-	-
Enable Write Status Register (EWSR) ⁷		50H	Hi-Z	-	-	-	-	-	-	-	-	-	-	-	-
Write Status Register (WRSR) ⁷		01H	Hi-Z	D _{IN} (S ₇ -S ₀)	Hi-Z	-	-	-	-	-	-	-	-	-	-
Write Enable (WREN) ¹⁰		06H	Hi-Z	-	-	-	-	-	-	-	-	-	-	-	-
Write Disable (WRDI)/ Exit secured OTP mode		04H	Hi-Z	-	-	-	-	-	-	-	-	-	-	-	-
Enter secured OTP mode (ENSO)		B1H	Hi-Z	-	-	-	-	-	-	-	-	-	-	-	-
Release from Deep Power Down (RDP)		ABH	Hi-Z	-	-	-	-	-	-	-	-	-	-	-	-
Read Electronic Signature (RES) ⁸	ABH	Hi-Z	X	X	X	X	X	X	X	15H	-	-	-	-	
RES in secured OTP mode & not lock down	ABH	Hi-Z	X	X	X	X	X	X	X	35H	-	-	-	-	
RES in secured OTP mode & lock down	ABH	Hi-Z	X	X	X	X	X	X	X	75H	-	-	-	-	

Table 5: Device Operation Instruction - Continued

Operation	Max. Freq	Bus Cycle ¹⁻³													
		1		2		3		4		5		6		N	
		S _{IN}	S _{OUT}	S _{IN}	S _{OUT}	S _{IN}	S _{OUT}	S _{IN}	S _{OUT}	S _{IN}	S _{OUT}	S _{IN}	S _{OUT}	S _{IN}	S _{OUT}
Jedec Read ID (JEDEC-ID) ⁹	50MHz	9FH	Hi-Z	X	8CH	X	20H	X	16H	-	-	-	-	-	-
Read ID (RDID) ¹¹	~							00H	Hi-Z	X	8CH	X	15H	-	-
	100MHz	90H	Hi-Z	00H	Hi-Z	00H	Hi-Z			X	15H	X	8CH	-	-

- Notes:
1. Operation: S_{IN} = Serial In, S_{OUT} = Serial Out, Bus Cycle 1 = Op Code
 2. X = Dummy Input Cycles (V_{IL} or V_{IH}); - = Non-Applicable Cycles (Cycles are not necessary); cont. = continuous
 3. One bus cycle is eight clock periods.
 4. Sector Erase addresses: use A_{MS} -A₁₂, remaining addresses can be V_{IL} or V_{IH}
Block Erase addresses: use A_{MS} -A₁₆, remaining addresses can be V_{IL} or V_{IH}
 5. To continue programming to the next sequential address location, enter the 8-bit command, followed by the data to be programmed.
 6. The Read-Status-Register is continuous with ongoing clock cycles until terminated by a low to high transition on \overline{CE} .
 7. The Enable-Write-Status-Register (EWSR) instruction and the Write-Status-Register (WRSR) instruction must work in conjunction of each other. The WRSR instruction must be executed immediately (very next bus cycle) after the EWSR instruction to make both instructions effective.
 8. The Read-Electronic-Signature is continuous with on going clock cycles until terminated by a low to high transition on \overline{CE} .
 9. The JEDEC-Read-ID is output first byte 8CH as manufacture ID; second byte 20H as top memory type; third byte 16H as memory capacity.
 10. The Write-Enable (WREN) instruction and the Write-Status-Register (WRSR) instruction must work in conjunction of each other. The WRSR instruction must be executed immediately (very next bus cycle) after the WREN instruction to make both instructions effective. Both EWSR and WREN can enable WRSR, user just need to execute one of it. A successful WRSR can reset WREN.
 11. The Manufacture ID and Device ID output will repeat continuously until \overline{CE} terminates the instruction.
 12. Dual commands use bidirectional IO pins. D_{OUT} and cont. are serial data out; others are serial data in.
 13. Dual output data:
 IO₀ = (D₆, D₄, D₂, D₀), (D₆, D₄, D₂, D₀)
 IO₁ = (D₇, D₅, D₃, D₁), (D₇, D₅, D₃, D₁)
 D_{OUT0} D_{OUT1}
 14. M₇-M₀: Mode bits. Dual input address:
 IO₀ = (A₂₂, A₂₀, A₁₈, A₁₆, A₁₄, A₁₂, A₁₀, A₈) (A₆, A₄, A₂, A₀, M₆, M₄, M₂, M₀)
 IO₁ = (A₂₃, A₂₁, A₁₉, A₁₇, A₁₅, A₁₃, A₁₁, A₉) (A₇, A₅, A₃, A₁, M₇, M₅, M₃, M₁)
 Bus Cycle-2 Bus Cycle-3
 15. This instruction is recommended when using the Dual Mode bit feature.

Read (33MHz)

The Read instruction supports up to 33 MHz, it outputs the data starting from the specified address location. The data output stream is continuous through all addresses until terminated by a low to high transition on \overline{CE} . The internal address pointer will automatically increment until the highest memory address is reached. Once the highest memory address is reached, the address pointer will automatically increment to the beginning (wrap-around) of the address space, i.e. for 32Mbit density, once

the data from address location 3FFFFFFH had been read, the next output will be from address location 000000H.

The Read instruction is initiated by executing an 8-bit command, 03H, followed by address bits [A₂₃-A₀]. \overline{CE} must remain active low for the duration of the Read cycle. See Figure 2 for the Read sequence.

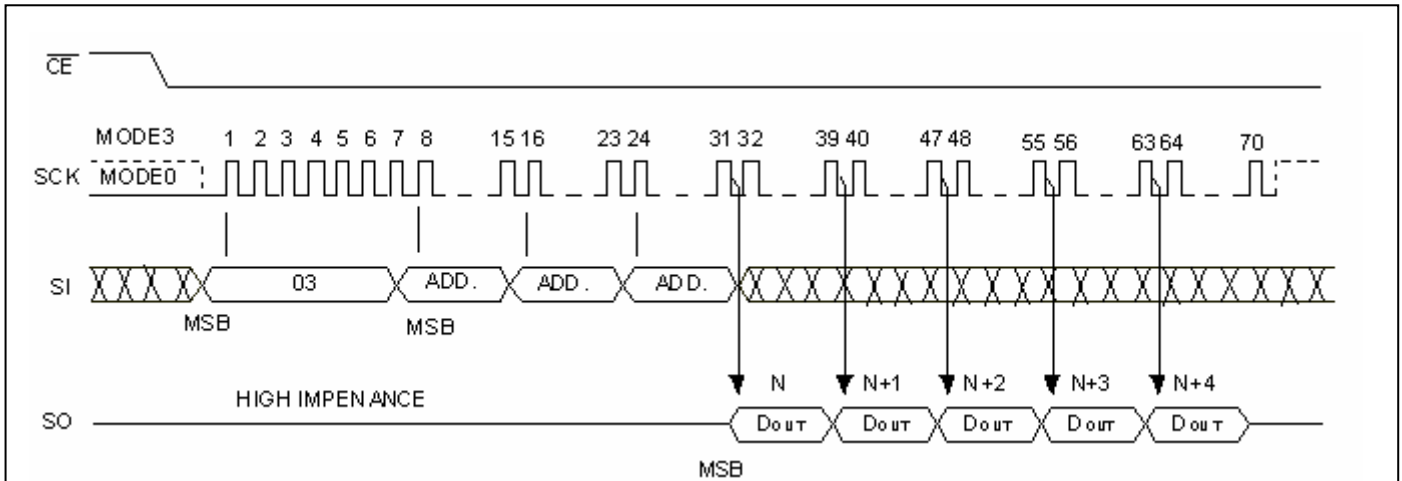

Figure 2: Read Sequence

Fast Read (50 MHz ~ 100 MHz)

The Fast Read instruction supporting up to 100 MHz is initiated by executing an 8-bit command, 0BH, followed by address bits [A₂₃-A₀] and a dummy byte. \overline{CE} must remain active low for the duration of the Fast Read cycle. See Figure 3 for the Fast Read sequence.

all addresses until terminated by a low to high transition on \overline{CE} . The internal address pointer will automatically increment until the highest memory address is reached. Once the highest memory address is reached, the address pointer will automatically increment to the beginning (wrap-around) of the address space, i.e. for 32Mbit density, once the data from address location 3FFFFFFH has been read, the next output will be from address location 000000H.

Following a dummy byte (8 clocks input dummy cycle), the Fast Read instruction outputs the data starting from the specified address location. The data output stream is continuous through

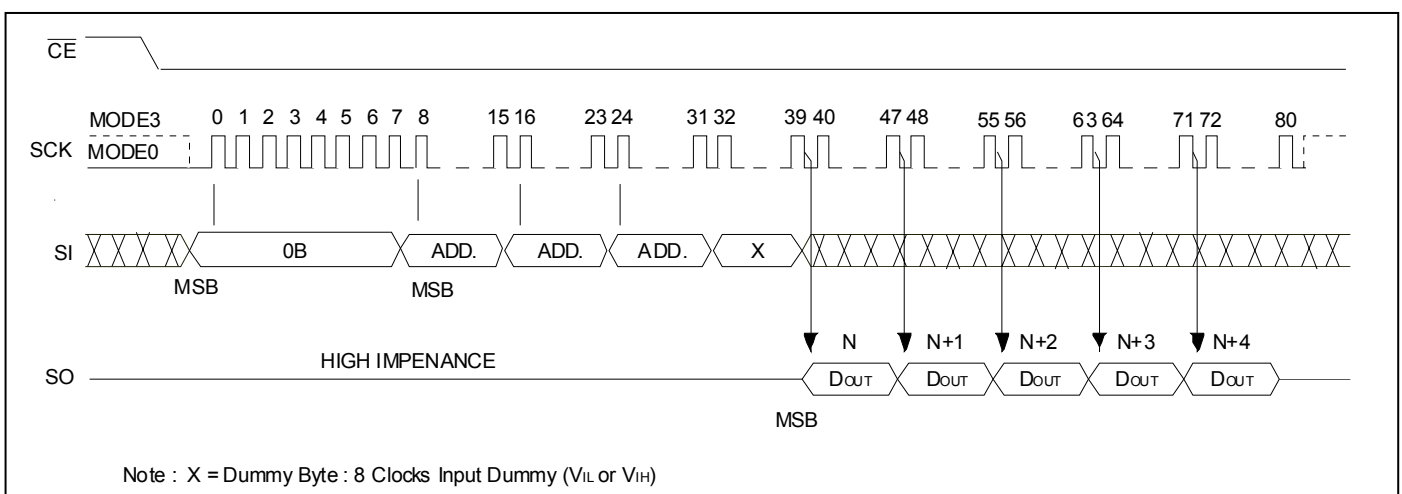

Figure 3: Fast Read Sequence

Fast Read Dual Output (50 MHz~100 MHz)

The Fast Read Dual Output (3BH) instruction is similar to the standard Fast Read (0BH) instruction except the data is output on bidirectional I/O pins (SIO₀ and SIO₁). This allows data to be transferred from the device at twice the rate of standard SPI devices. This instruction is for quickly downloading code from Flash to RAM upon power-up or for applications that cache code-segments to RAM for execution.

The Fast Read Dual Output instruction is initiated by executing an 8-bit command, 3BH, followed by address bits [A₂₃-A₀] and a dummy byte. \overline{CE} must remain active low for the duration of the Fast Read Dual Output cycle. See Figure 4 for the Fast Read Dual Output sequence.

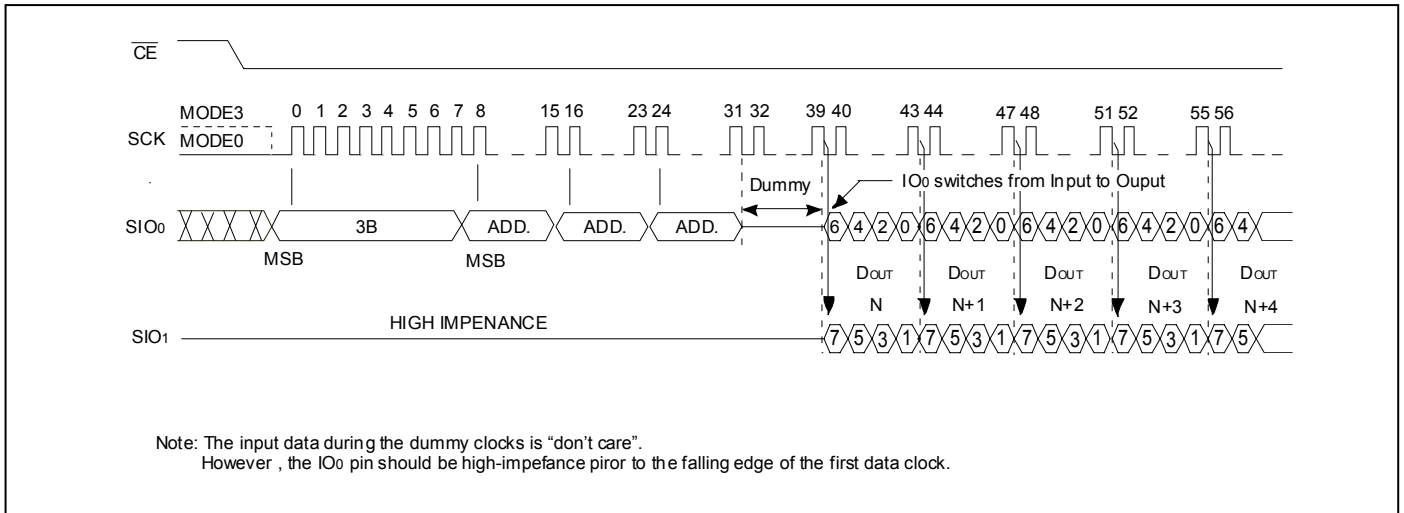

Figure 4: Fast Read Dual Output Sequence

Fast Read Dual I/O (50 MHz~100 MHz)

The Fast Read Dual I/O (BBH) instruction is similar to the Fast Read Dual Output (3BH) instruction, but with the capability to input address bits $[A_{23}-A_0]$ two bits per clock.

To set mode bits $[M_7-M_0]$ after the address bits $[A_{23}-A_0]$ can further reduce instruction overhead (See Figure 5). The upper mode bits $[M_7-M_4]$ controls the length of next Fast Read Dual I/O instruction with/without the first byte command code (BBH). The lower mode bits $[M_3-M_0]$ are "don't care".

If $[M_7-M_0] = "AxH"$, the next Fast Read Dual I/O instruction (after \overline{CE} is raised and the lowered) doesn't need the command code (See Figure 6). This way let the instruction sequence reduce 8 clocks and allows to enter address immediately after \overline{CE} is asserted low. If $[M_7-M_0]$ are the value other than "AxH", the next instruction need the first byte command code, thus returning to normal operation. A Mode Bit Reset (FFH) also can be used to reset mode bits $[M_7-M_0]$ before issuing normal instructions.

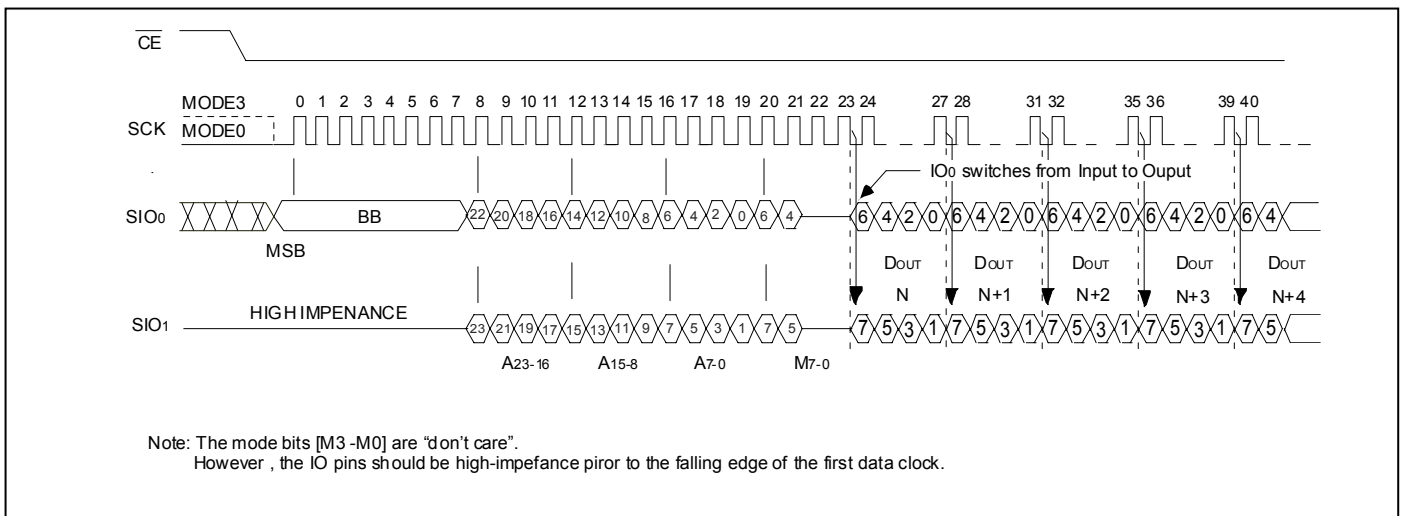

Figure 5: Fast Read Dual I/O Sequence ($[M_7-M_0] = 0xH$ or NOT AxH)

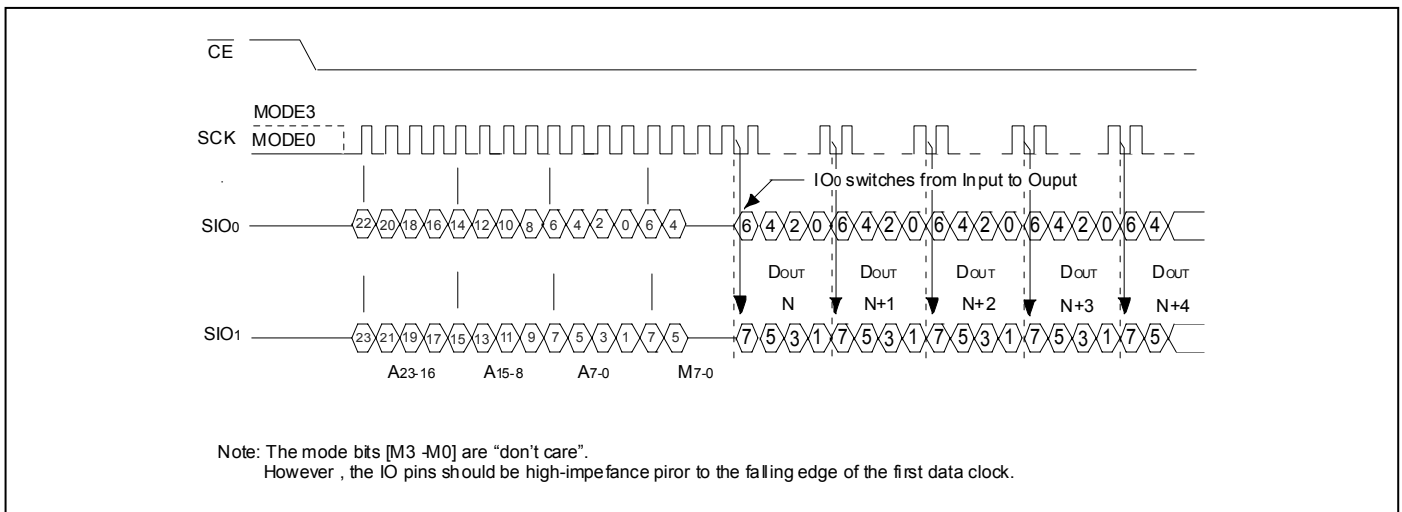

Figure 6: Fast Read Dual I/O Sequence ($[M_7-M_0] = AxH$)

Page Program (PP)

The Page Program instruction allows many bytes to be programmed in the memory. The bytes must be in the erased state (FFH) when initiating a Program operation. A Page Program instruction applied to a protected memory area will be ignored.

Prior to any Write operation, the Write Enable (WREN) instruction must be executed. \overline{CE} must remain active low for the duration of the Page Program instruction. The Page Program instruction is initiated by executing an 8-bit command, 02H, followed by address bits [A₂₃-A₀]. Following the address, at least one byte Data is input (the maximum of input data can be up to 256 bytes). If the 8 least significant address bits [A₇-A₀] are not all zero, all transmitted data that goes beyond the end of the current page are programmed from the start address of the same page (from the address whose 8 least significant bits [A₇-A₀] are all zero).

If more than 256 bytes Data are sent to the device, previously

latched data are discarded and the last 256 bytes Data are guaranteed to be programmed correctly within the same page. If less than 256 bytes Data are sent to device, they are correctly programmed at the requested addresses without having any effects on the other bytes of the same page.

\overline{CE} must be driven high before the instruction is executed. The user may poll the BUSY bit in the software status register or wait T_{PP} for the completion of the internal self-timed Page Program operation. While the Page Program cycle is in progress, the Read Status Register instruction may still be accessed for checking the status of the BUSY bit. It is recommended to wait for a duration of T_{BP4} before reading the status register to check the BUSY bit. The BUSY bit is a 1 during the Page Program cycle and becomes a 0 when the cycle is finished and the device is ready to accept other instructions again. After the Page Program cycle has finished, the Write-Enable-Latch (WEL) bit in the Status Register is cleared to 0. See Figure 10 for the Page Program sequence.

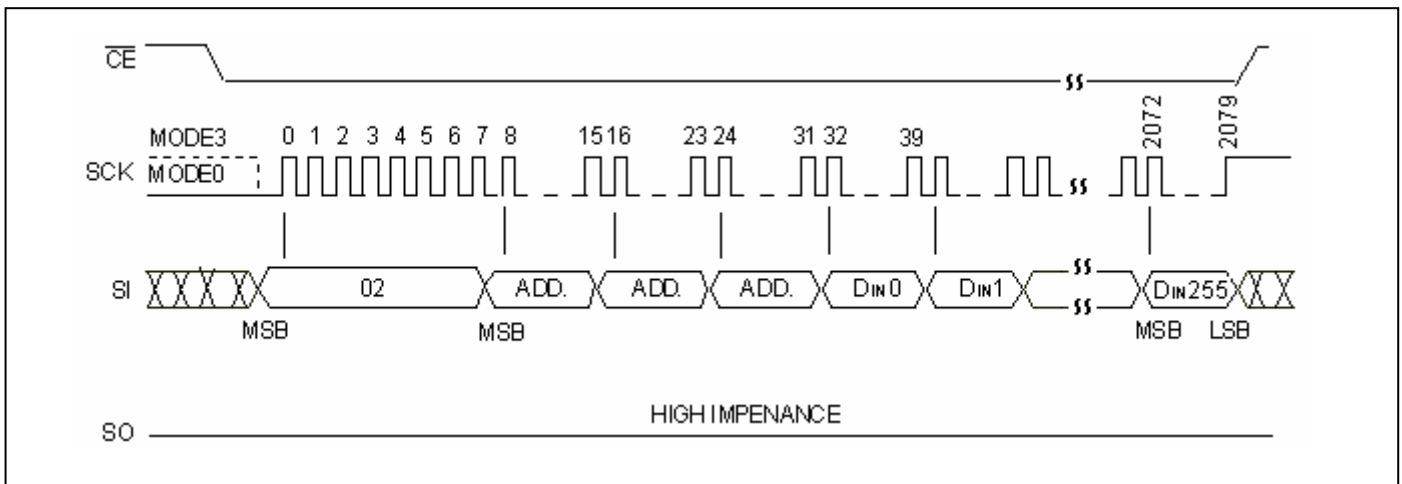

Figure 10: Page Program Sequence

Mode Bit Reset

Mode bits [M₇–M₀] are issued to further reduce instruction overhead for Fast Read Dual I/O operation. If [M₇–M₀] = “AxH”, the next Fast Read Dual I/O instruction doesn’t need the command code.

If the system controller is reset during operation, it will send a standard instruction (such as Read ID) to the Flash memory.

However, the device doesn’t have a hardware reset pin, so if [M₇–M₀] = “AxH”, the device will not recognize any standard SPI instruction. After a system reset, it is recommended to issue a Mode Bit Reset instruction first to release the status of [M₇–M₀] = “AxH” and allow the device to recognize standard SPI instruction. See Figure 16 for the Mode Bit Reset instruction.

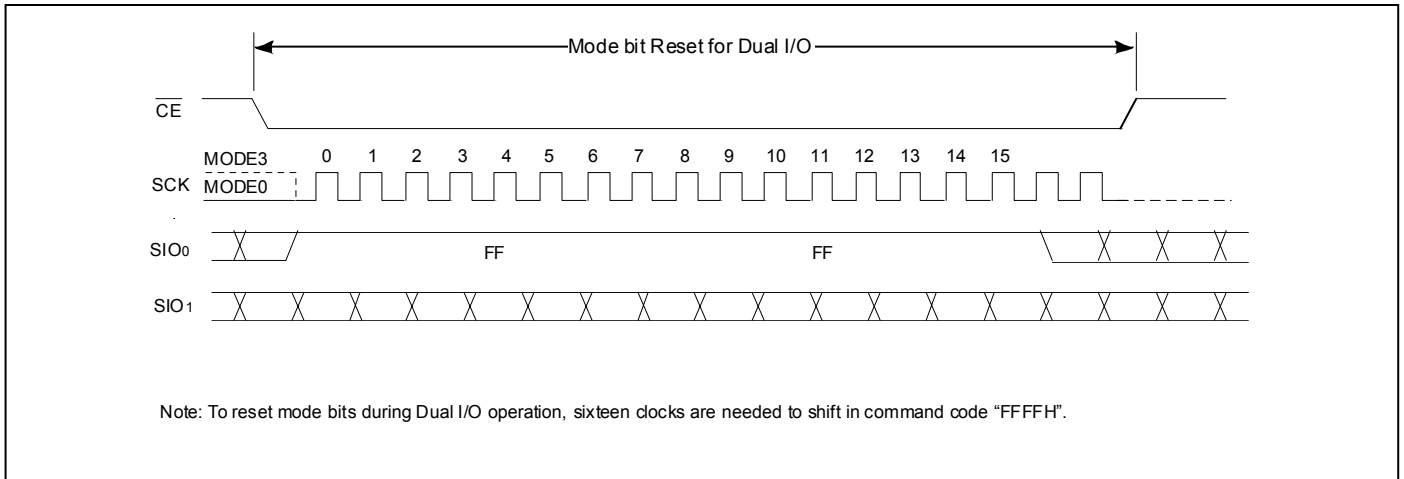

Figure 16: Mode Bit Reset Instruction

64K Byte Block Erase

The 64K-byte Block Erase instruction clears all bits in the selected block to FFH. A Block Erase instruction applied to a protected memory area will be ignored. Prior to any Write operation, the Write Enable (WREN) instruction must be executed. \overline{CE} must remain active low for the duration of the any command sequence. The Block Erase instruction is initiated by executing an 8-bit command, D8H, followed by address bits [A₂₃

-A₀]. Address bits [A_{MS}-A₁₆] (A_{MS} = Most Significant address) are used to determine the block address (BA_x), remaining address bits can be V_{IL} or V_{IH}. \overline{CE} must be driven high before the instruction is executed. The user may poll the BUSY bit in the Software Status Register or wait T_{BE} for the completion of the internal self-timed Block Erase cycle. See Figure 17 for the Block Erase sequence.

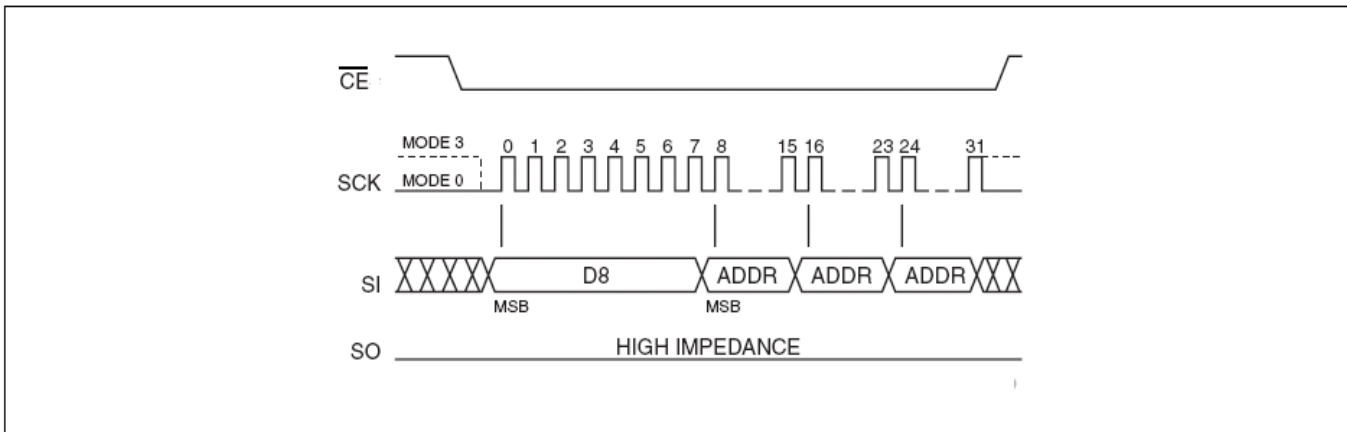

Figure 17: 64K-byte Block Erase Sequence

4K Byte Sector Erase

The Sector Erase instruction clears all bits in the selected sector to FFH. A Sector Erase instruction applied to a protected memory area will be ignored. Prior to any Write operation, the Write Enable (WREN) instruction must be executed. \overline{CE} must remain active low for the duration of the any command sequence. The Sector Erase instruction is initiated by executing an 8-bit command, 20H, followed by address bits [A₂₃-A₀]. Address bits

[A_{MS}-A₁₂] (A_{MS} = Most Significant address) are used to determine the sector address (SA_x), remaining address bits can be V_{IL} or V_{IH}. \overline{CE} must be driven high before the instruction is executed. The user may poll the BUSY bit in the Software Status Register or wait T_{SE} for the completion of the internal self-timed Sector Erase cycle. See Figure 18 for the Sector Erase sequence.

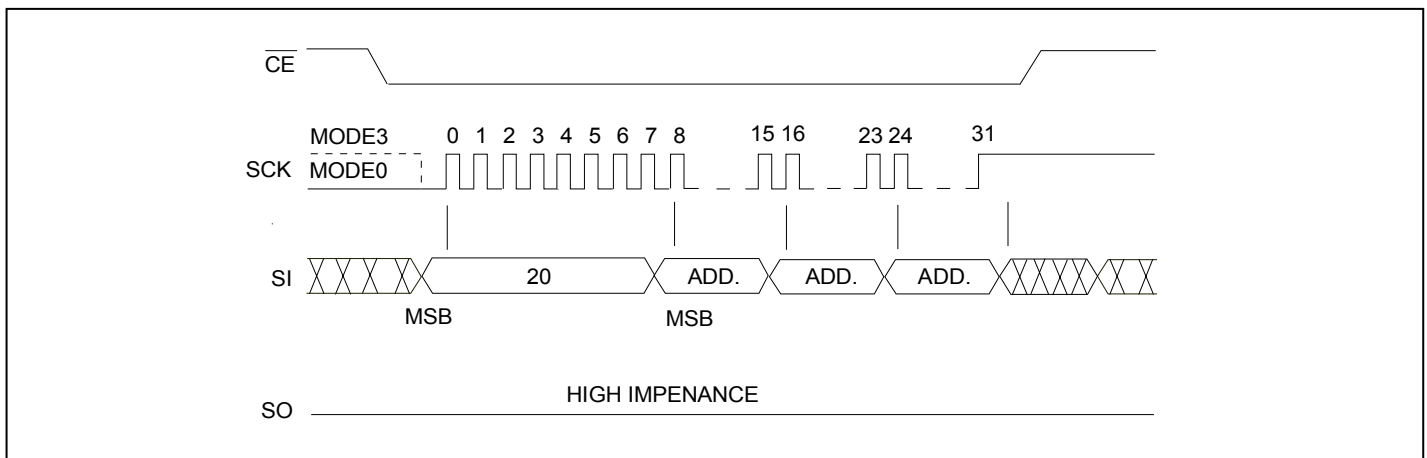

Figure 18: 4K-byte Sector Erase Sequence

Chip Erase

The Chip Erase instruction clears all bits in the device to FFH. A Chip Erase instruction will be ignored if any of the memory area is protected. Prior to any Write operation, the Write Enable (WREN) instruction must be executed. \overline{CE} must remain active low for the duration of the Chip-Erase instruction sequence. The Chip

Erase instruction is initiated by executing an 8-bit command, 60H or C7H. \overline{CE} must be driven high before the instruction is executed. The user may poll the BUSY bit in the Software Status Register or wait T_{CE} for the completion of the internal self-timed Chip Erase cycle. See Figure 19 for the Chip Erase sequence.

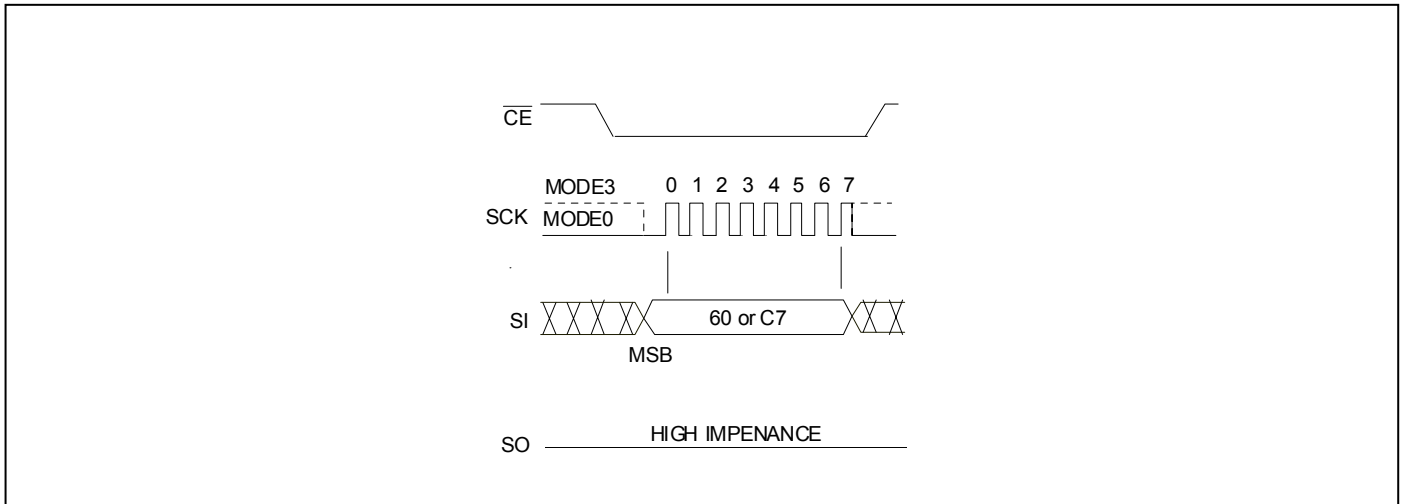

Figure 19: Chip Erase Sequence

Read Status Register (RDSR)

The Read Status Register (RDSR) instruction allows reading of the status register. The status register may be read at any time even during a Write (Program/Erase) operation. When a Write operation is in progress, the BUSY bit may be checked before sending any new commands to assure that the new commands are properly received by the device.

\overline{CE} must be driven low before the RDSR instruction is entered and remain low until the status data is read. The RDSR-1 instruction code is "05H" for Status Register. Read Status Register is continuous with ongoing clock cycles until it is terminated by a low to high transition of the \overline{CE} . See Figure 20 for the RDSR instruction sequence.

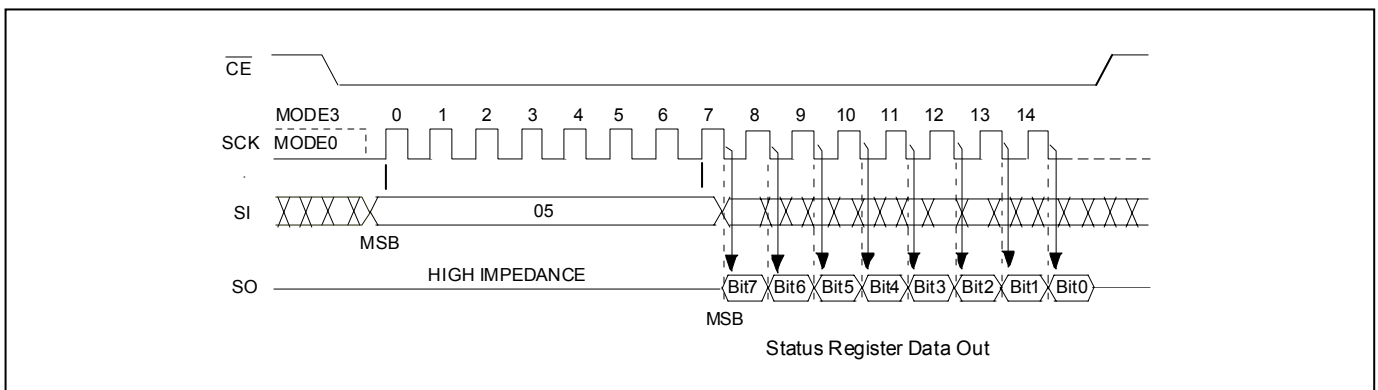

Figure 20: Read Status Register (RDSR) Sequence

Write Enable (WREN)

The Write Enable (WREN) instruction sets the Write-Enable-Latch bit in the Software Status Register to 1 allowing Write operations to occur. The WREN instruction must be executed prior to any Write

(Program/Erase) operation. \overline{CE} must be driven high before the WREN instruction is executed.

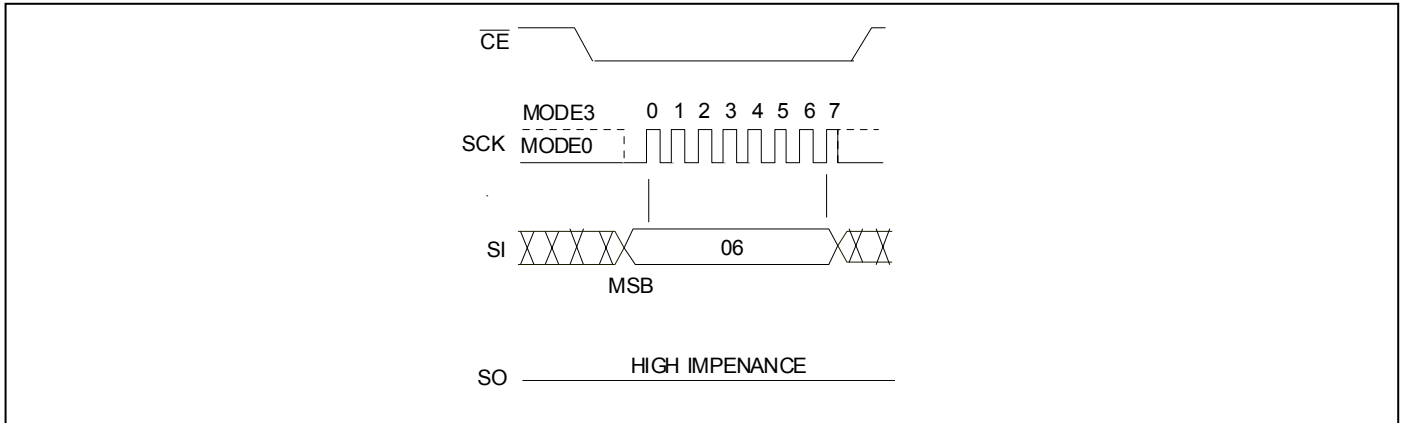

Figure 21: Write Enable (WREN) Sequence

Write Disable (WRDI)

The Write Disable (WRDI) instruction resets the Write-Enable-Latch bit to 0 disabling any new Write operations from occurring or exits from OTP mode to normal mode.

\overline{CE} must be driven high before the WRDI instruction is executed.

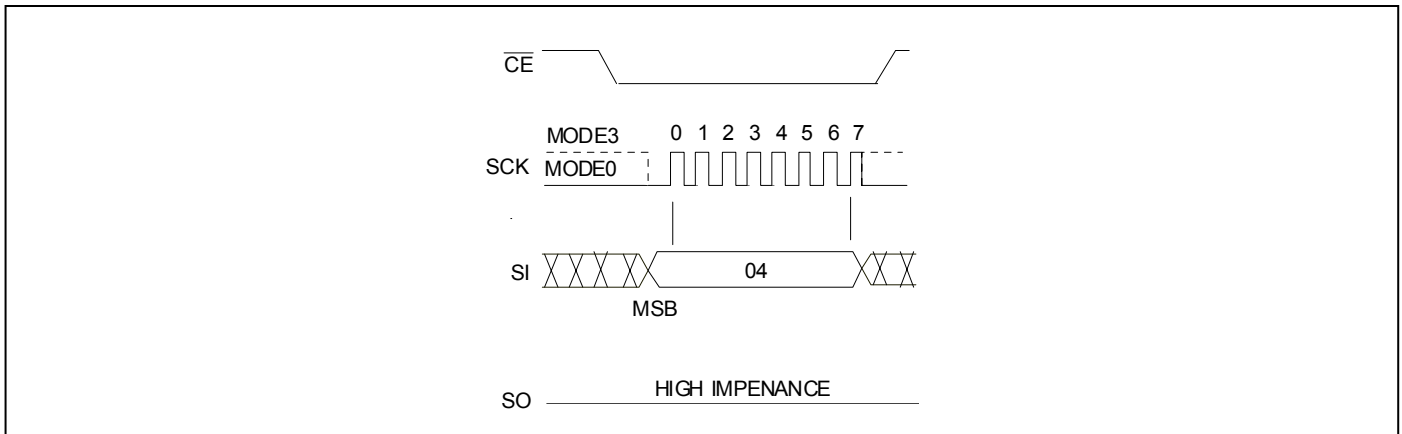

Figure 22: Write Disable (WRDI) Sequence

Enable Write Status Register (EWSR)

The Enable Write Status Register (EWSR) instruction arms the Write Status Register (WRSR) instruction and opens the status register for alteration. The Enable Write Status Register instruction does not have any effect and will be wasted, if it is not followed immediately by the Write Status Register (WRSR)

instruction. \overline{CE} must be driven low before the EWSR instruction is entered and must be driven high before the EWSR instruction is executed.

Write Status Register (WRSR)

The Write Status Register instruction writes new values to the BP2, BP1, BP0, BPL (Status Register) bits of the status register.

\overline{CE} must be driven low before the command sequence of the WRSR instruction is entered and driven high before the WRSR instruction is executed. \overline{CE} must be driven high after the eighth bit of data that is clocked in. If it is not done, the WRSR instruction will not be issued. See Figure 23 for EWSR or WREN and WRSR instruction sequences.

Executing the Write Status Register instruction will be ignored when \overline{WP} is low and BPL bit is set to "1". When the \overline{WP} is low, the BPL bit can only be set from "0" to "1" to lock down the status register, but cannot be reset from "1" to "0".

When \overline{WP} is high, the lock-down function of the BPL bit is disabled and the BPL, BP0, BP1, and BP2 bits in the status register can all be changed. As long as BPL bit is set to 0 or \overline{WP} pin is driven high (V_{IH}) prior to the low-to-high transition of the \overline{CE} pin at the end of the WRSR instruction, the bits in the status register can all be altered by the WRSR instruction. In this case, a single WRSR instruction can set the BPL bit to "1" to lock down the status register as well as altering the BP0; BP1 and BP2 bits at the same time. See Table 4 for a summary description of \overline{WP} and BPL functions.

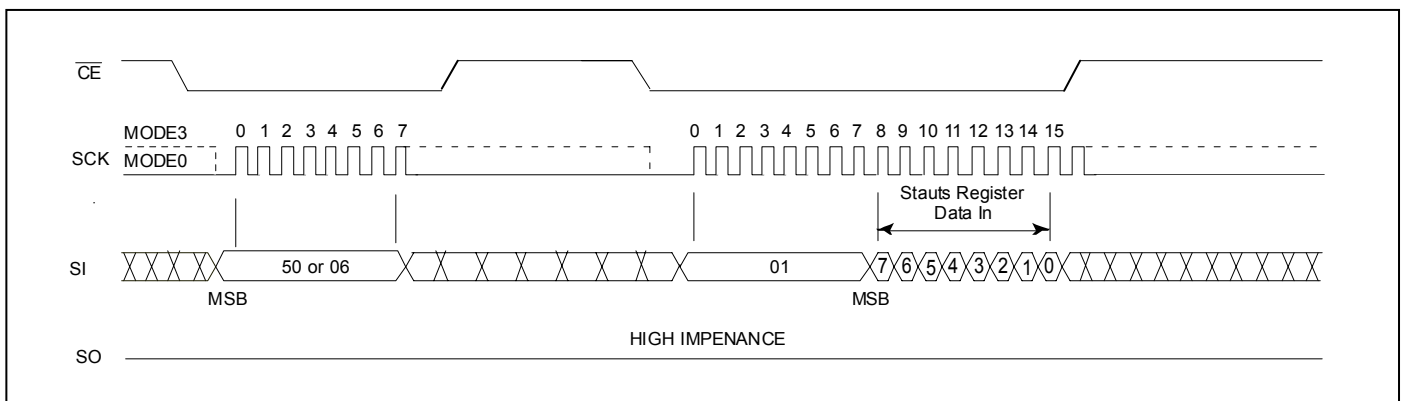

Figure 23: Enable Write Status Register (EWSR) or Write Enable (WREN) and Write Status Register (WRSR)

Enter OTP Mode (ENSO)

The ENSO (B1H) instruction is for entering the additional 512 bytes secured OTP mode. The additional 512 bytes secured OTP sector is independent from main array, which may use to store unique serial number for system identifier. User must unprotect whole array (BP0=BP1=BP2=0), prior to any Program operation in OTP sector. After entering the secured OTP mode, only the secured OTP sector can be accessed and user can only follow the Read or Program procedure with OTP address range

(address bits [A₂₃ –A₉] must be "0"). The secured OTP data cannot be updated again once it is lock down or has been programmed. In secured OTP mode, WRSR command will ignore the input data and lock down the secured OTP sector (OTP_lock bit =1). To exit secured OTP mode, user must execute WRDI command. RES can be used to verify the secured OTP status as shown in Table 6.

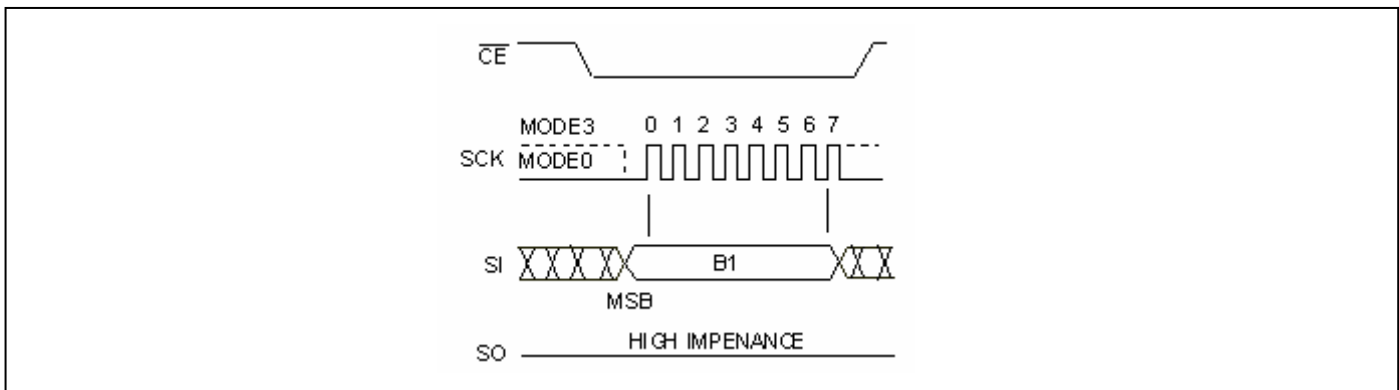

Figure 24: Enter OTP Mode (ENSO) Sequence

OTP Sector Address

Size	Address Range
512 bytes	000000H ~ 0001FFH

Note: The OTP sector is an independent Sector.

Deep Power Down (DP)

The Deep Power Down instruction is for minimizing power consumption (the standby current is reduced from I_{SB1} to I_{SB2}).

This instruction is initiated by executing an 8-bit command, B9H, and then \overline{CE} must be driven high. After \overline{CE} is driven high, the device will enter to deep power down within the duration of T_{DP} .

Once the device is in deep power down status, all instructions will be ignored except the Release from Deep Power Down instruction (RDP) and Read Electronic Signature instruction (RES). The device always power-up in the normal operation with the standby current (I_{SB1}). See Figure 25 for the Deep Power Down instruction.

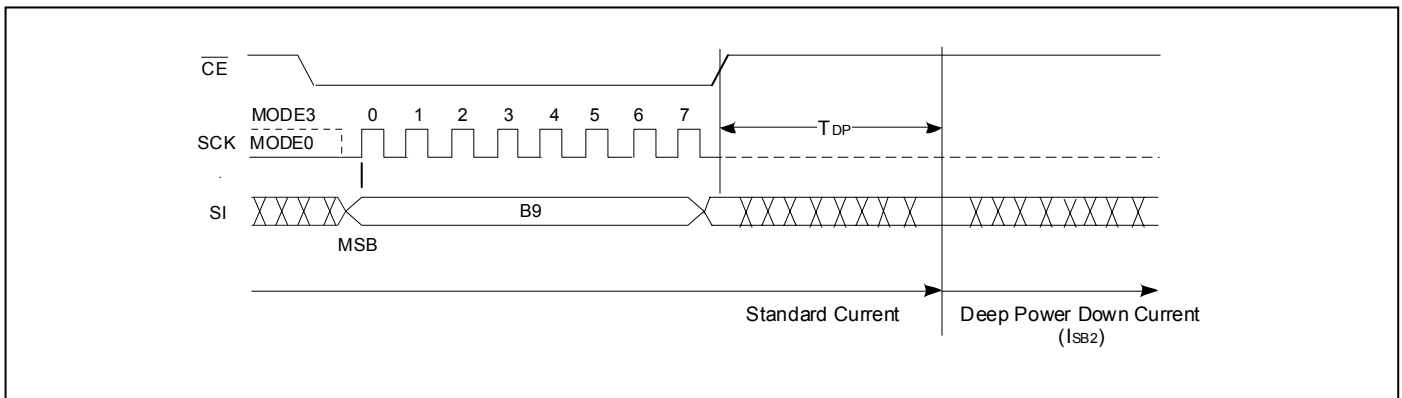

Figure 25: Deep Power Down Instruction

Release from Deep Power Down (RDP) and Read Electronic-Signature (RES)

The Release from Deep Power Down and Read Electronic-Signature instruction is a multi-purpose instruction.

The instruction can be used to release the device from the deep power down status. This instruction is initiated by driving \overline{CE} low and executing an 8-bit command, ABH, and then drive \overline{CE} high. See Figure 26 for RDP instruction. Release from the deep power down will take the duration of T_{RES1} before the device will resume normal operation and other instructions are accepted. \overline{CE} must remain high during T_{RES1} .

The instruction also can be used to read the 8-bit Electronic-Signature of the device on the SO pin. It is initiated by driving

\overline{CE} low and executing an 8-bit command, ABH, followed by 3 dummy bytes. The Electronic-Signature byte is then output from the device. The Electronic-Signature can be read continuously until \overline{CE} go high. See Figure 27 for RES sequence. After driving \overline{CE} high, it must remain high during for the duration of T_{RES2} , and then the device will resume normal operation and other instructions are accepted.

The instruction is executed while an Erase, Program or WRSR cycle is in progress is ignored and has no effect on the cycle in progress. In OTP mode, user also can execute RES to confirm the status of OTP.

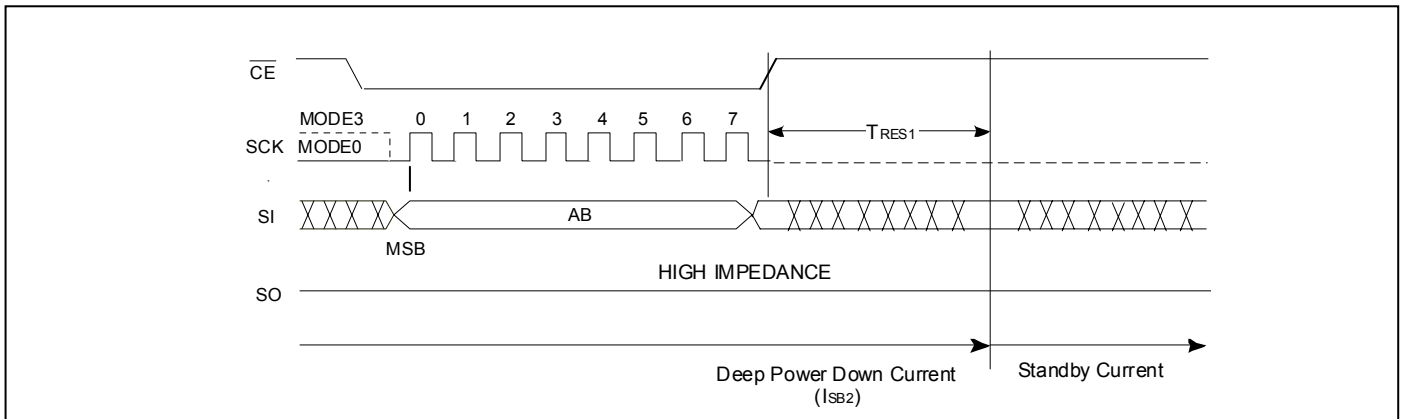

Figure 26: Release from Deep Power Down (RDP) Instruction

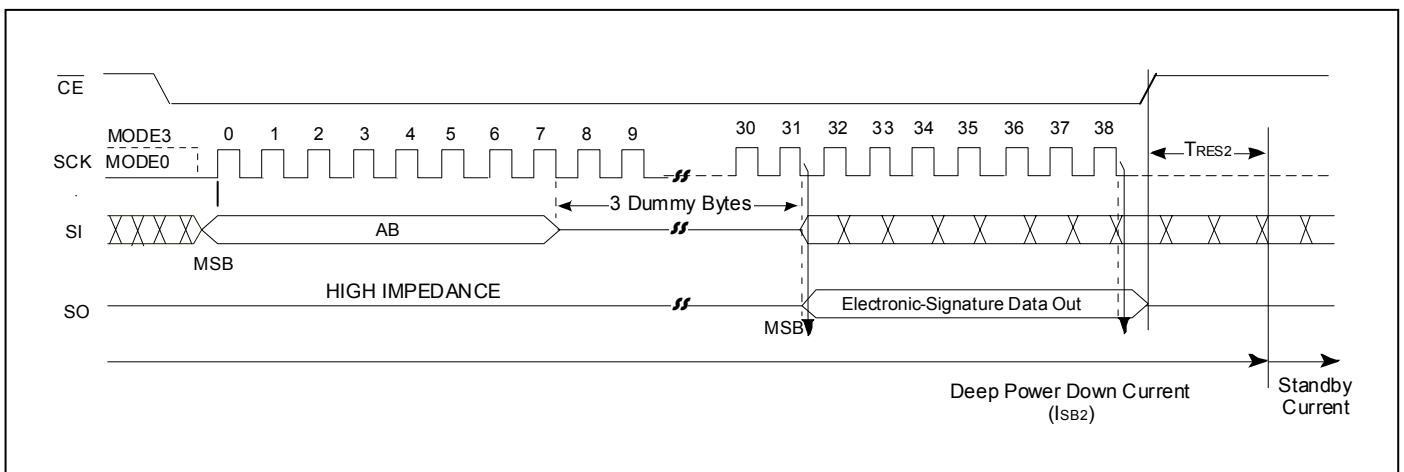

Figure 27: Read Electronic -Signature (RES) Sequence

Table 6: Electronic Signature Data

Command	Mode	Electronic Signature Data
RES	Normal	15H
	In secured OTP mode & non lock down (OTP_lock =0)	35H
	In secured OTP mode & lock down (OTP_lock =1)	75H

JEDEC Read-ID

The JEDEC Read-ID instruction identifies the device as F25L32PA and the manufacturer as ESMT. The device information can be read from executing the 8-bit command, 9FH. Following the JEDEC Read-ID instruction, the 8-bit manufacturer's ID, 8CH, is output from the device. After that, a 16-bit device ID is shifted out on the SO pin. Byte1, 8CH, identifies the manufacturer as ESMT. Byte2, 20H, identifies the memory type as SPI Flash. Byte3, 16H, identifies the device as F25L32PA. The instruction sequence is shown in Figure 28.

The JEDEC Read ID instruction is terminated by a low to high transition on \overline{CE} at any time during data output. If no other command is issued after executing the JEDEC Read-ID instruction, issue a 00H (NOP) command before going into Standby Mode ($\overline{CE} = V_{IH}$).

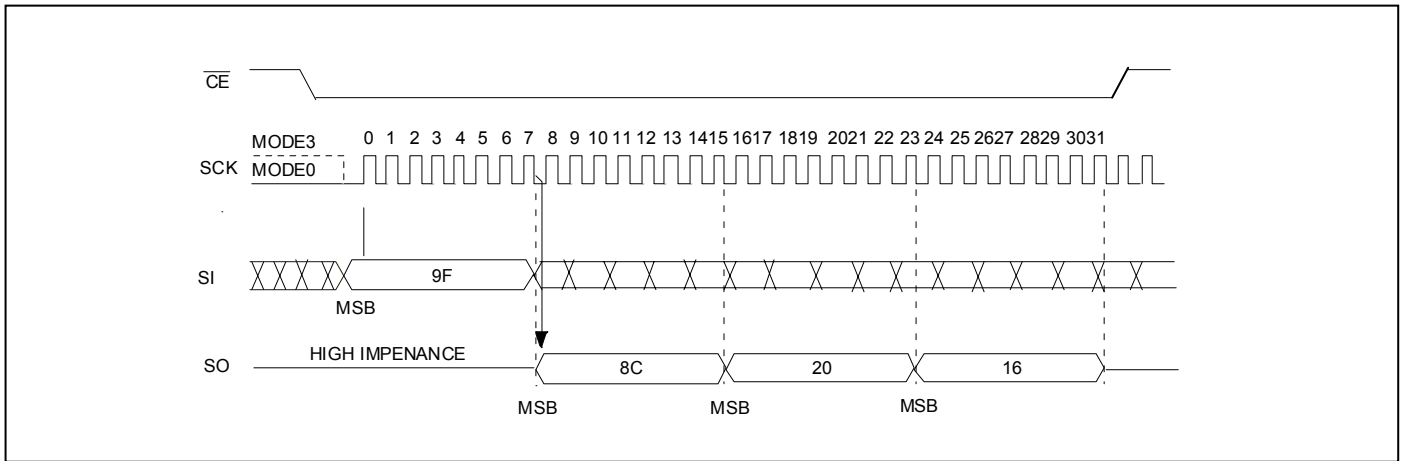

Figure 28: JEDEC Read-ID Sequence

Table 7: JEDEC Read-ID Data

Manufacturer's ID (Byte 1)	Device ID	
	Memory Type (Byte 2)	Memory Capacity (Byte 3)
8CH	20H	16H

Read-ID (RDID)

The Read-ID instruction (RDID) identifies the devices as F25L32PA and manufacturer as ESMT. This command is backward compatible to all ESMT SPI devices and should be used as default device identification when multiple versions of ESMT SPI devices are used in one design. The device information can be read from executing an 8-bit command, 90H, followed by address bits [A₂₃ -A₀]. Following the Read-ID

instruction, the manufacturer's ID is located in address 000000H and the device ID is located in address 000001H. Once the device is in Read-ID mode, the manufacturer's and device ID output data toggles between address 000000H and 000001H until terminated by a low to high transition on \overline{CE} .

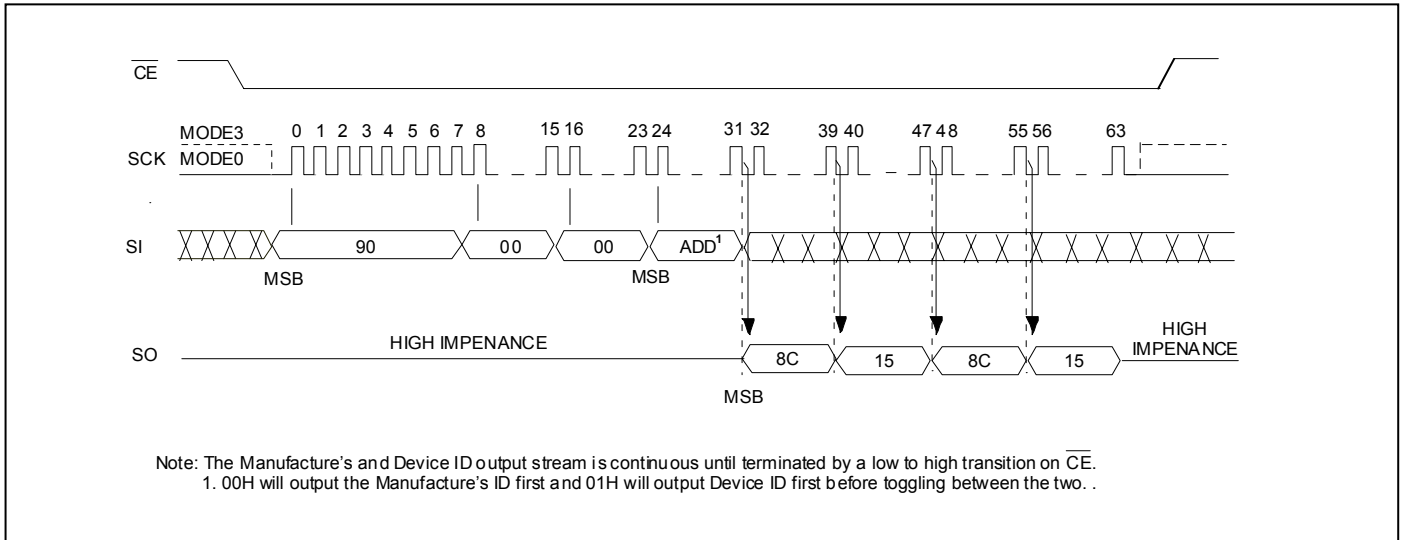

Figure 29: Read ID Sequence

Table 8: Product ID Data

Address	Byte1	Byte2
000000H	8CH	15H
	Manufacturer's ID	Device ID ESMT F25L32PA
000001H	15H	8CH
	Device ID ESMT F25L32PA	Manufacturer's ID

■ ELECTRICAL SPECIFICATIONS

Absolute Maximum Stress Ratings

(Applied conditions are greater than those listed under “Absolute Maximum Stress Ratings” may cause permanent damage to the device. This is a stress rating only and functional operation of the device at these conditions or conditions greater than those defined in the operational sections of this datasheet is not implied. Exposure to absolute maximum stress rating conditions may affect device reliability.)

Storage Temperature	-65°C to +150°C
D. C. Voltage on Any Pin to Ground Potential	-0.5V to VDD+0.5V
Transient Voltage (<20 ns) on Any Pin to Ground Potential	-2.0V to VDD+2.0V
Package Power Dissipation Capability (T _A = 25°C)	1.0W
Surface Mount Lead Soldering Temperature (3 Seconds)	240°C
Output Short Circuit Current (Note 1)	50 mA

(Note 1: Output shorted for no more than one second. No more than one output shorted at a time.)

TABLE 9: AC CONDITIONS OF TEST

Input Rise/Fall Time	5 ns
Output Load	C _L = 15 pF for ≥ 75MHz
.....	C _L = 30 pF for ≤ 50MHz
See Figures 34 and 35	

TABLE 10: OPERATING RANGE

Parameter	Symbol	Value	Unit
Operating Supply Voltage	V _{DD}	2.7 ~ 3.6	V
	V _{DD} (F _{CLK} > 50MHz)	3.0 ~ 3.6	V
Ambient Operating Temperature	T _A	0 ~ 70	°C

TABLE 11: DC OPERATING CHARACTERISTICS

Symbol	Parameter	Limits			Test Condition
		Min	Max	Unit	
I _{DDR1}	Read Current @ 33MHz	Standard	15	mA	$\overline{CE} = 0.1 V_{DD}/0.9 V_{DD}$, SO=open
		Dual	18		
I _{DDR2}	Read Current @ 50MHz	Standard	20	mA	$\overline{CE} = 0.1 V_{DD}/0.9 V_{DD}$, SO=open
		Dual	23		
I _{DDR3}	Read Current @ 86MHz	Standard	23	mA	$\overline{CE} = 0.1 V_{DD}/0.9 V_{DD}$, SO=open
		Dual	25		
I _{DDR4}	Read Current @ 100MHz	Standard	25	mA	$\overline{CE} = 0.1 V_{DD}/0.9 V_{DD}$, SO=open
		Dual	28		
I _{DDW}	Program and Erase Current		35	mA	$\overline{CE} = V_{DD}$
I _{SB1}	Standby Current		30	µA	$\overline{CE} = V_{DD}$, V _{IN} =V _{DD} or V _{SS}
I _{SB2}	Deep Power Down Current		5	µA	$\overline{CE} = V_{DD}$, V _{IN} =V _{DD} or V _{SS}
I _{LI}	Input Leakage Current		1	µA	V _{IN} =GND to V _{DD} , V _{DD} =V _{DD} Max
I _{LO}	Output Leakage Current		1	µA	V _{OUT} =GND to V _{DD} , V _{DD} =V _{DD} Max
V _{IL}	Input Low Voltage		0.8	V	V _{DD} =V _{DD} Min
V _{IH}	Input High Voltage	0.7 x V _{DD}		V	V _{DD} =V _{DD} Max
V _{OL}	Output Low Voltage		0.2	V	I _{OL} =100 µA, V _{DD} =V _{DD} Min
V _{OH}	Output High Voltage	V _{DD} -0.2		V	I _{OH} =-100 µA, V _{DD} =V _{DD} Min

TABLE 12: LATCH UP CHARACTERISTIC

Symbol	Parameter	Minimum	Unit	Test Method
I_{LTH}^1	Latch Up	$100 + I_{DD}$	mA	JEDEC Standard 78

Note 1: This parameter is measured only for initial qualification and after a design or process change that could affect this parameter.

TABLE 13: CAPACITANCE (TA = 25°C, f=1 MHz, other pins open)

Parameter	Description	Test Condition	Maximum
C_{OUT}^1	Output Pin Capacitance	$V_{OUT} = 0V$	12 pF
C_{IN}^1	Input Capacitance	$V_{IN} = 0V$	6 pF

Note 1: This parameter is measured only for initial qualification and after a design or process change that could affect this parameter.

TABLE 14: AC OPERATING CHARACTERISTICS

Symbol	Parameter	Normal 33 MHz		Fast 50 MHz		Fast 86 MHz		Fast 100 MHz		Unit
		Min	Max	Min	Max	Min	Max	Min	Max	
F_{CLK}	Serial Clock Frequency		33		50		86		100	MHz
T_{SCKH}	Serial Clock High Time	13		9		7		5		ns
T_{SCKL}	Serial Clock Low Time	13		9		7		5		ns
T_{CES}^1	\overline{CE} Active Setup Time	5		5		5		5		ns
T_{CEH}^1	\overline{CE} Active Hold Time	5		5		5		5		ns
T_{CHS}^1	\overline{CE} Not Active Setup Time	5		5		5		5		ns
T_{CHH}^1	\overline{CE} Not Active Hold Time	5		5		5		5		ns
T_{CPH}	\overline{CE} High Time	100		100		100		100		ns
T_{CHZ}	\overline{CE} High to High-Z Output		9		9		9		9	ns
T_{CLZ}	SCK Low to Low-Z Output	0		0		0		0		ns
T_{DS}	Data In Setup Time	3		3		3		3		ns
T_{DH}	Data In Hold Time	3		3		3		3		ns
T_{HLS}	\overline{HOLD} Low Setup Time	5		5		5		5		ns
T_{HHS}	\overline{HOLD} High Setup Time	5		5		5		5		ns
T_{HLH}	\overline{HOLD} Low Hold Time	5		5		5		5		ns
T_{HHH}	\overline{HOLD} High Hold Time	5		5		5		5		ns
T_{HZ}	\overline{HOLD} Low to High-Z Output		9		9		9		9	ns

TABLE 14: AC OPERATING CHARACTERISTICS - Continued

Symbol	Parameter	Normal 33MHz		Fast 50 MHz		Fast 86 MHz		Fast 100 MHz		Unit
		Min	Max	Min	Max	Min	Max	Min	Max	
T _{LZ}	$\overline{\text{HOLD}}$ High to Low-Z Output		9		9		9		9	ns
T _{OH}	Output Hold from SCK Change	0		0		0		0		ns
T _V	Output Valid from SCK		12		8		8		8	ns
T _{DP}	$\overline{\text{CE}}$ High to Deep Power Down Mode		3		3		3		3	us
T _{RES1}	$\overline{\text{CE}}$ High to Standby Mode (for DP)		3		3		3		3	us
T _{RES2}	$\overline{\text{CE}}$ High to Standby Mode (for RES)		1.8		1.8		1.8		1.8	us

Note 1: Relative to SCK.

TABLE 15: ERASE AND PROGRAMMING PERFORMANCE

Parameter	Symbol	Limit		Unit
		Typ ²	Max ³	
Sector Erase Time	T _{SE}	90	300	ms
Block Erase Time	T _{BE}	1	2	s
Chip Erase Time	T _{CE}	25	50	s
Byte Programming Time	T _{BP}	7	30	us
Page Programming Time	T _{PP}	1.5	5	ms
Chip Programming Time		50	100	s
Erase/Program Cycles ¹		100,000	-	Cycles
Data Retention		20	-	Years

Notes:

1. Not 100% Tested, Excludes external system level over head.
2. Typical values measured at 25°C, 3V.
3. Maximum values measured at 85°C, 2.7V.

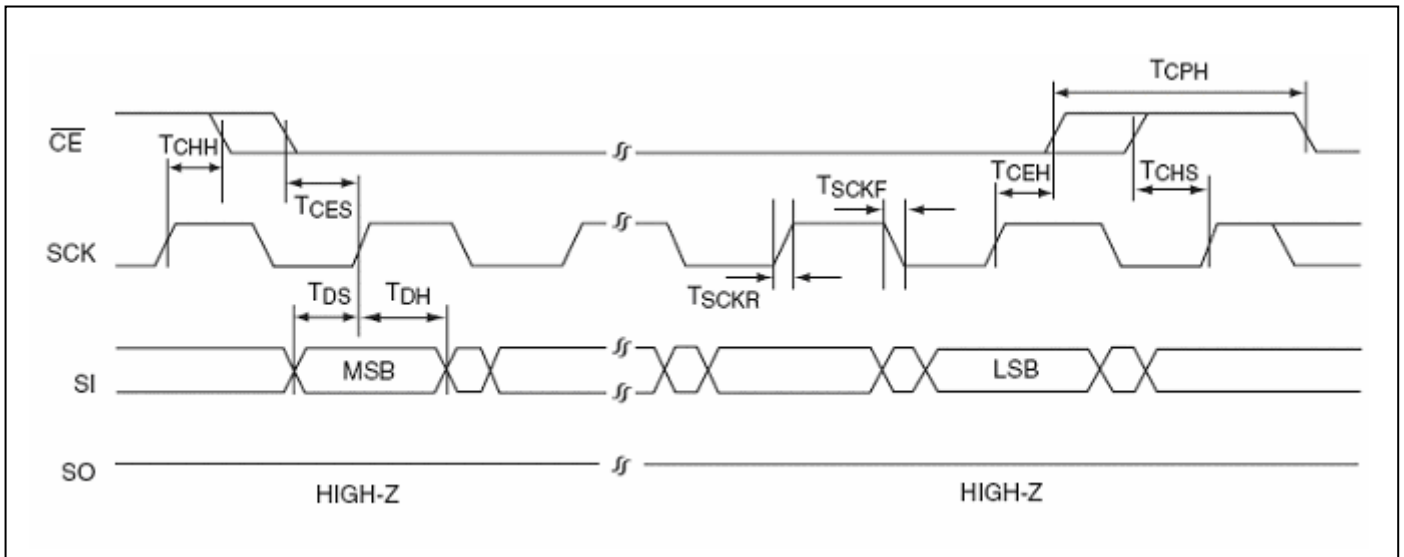

Figure 30: Serial Input Timing Diagram

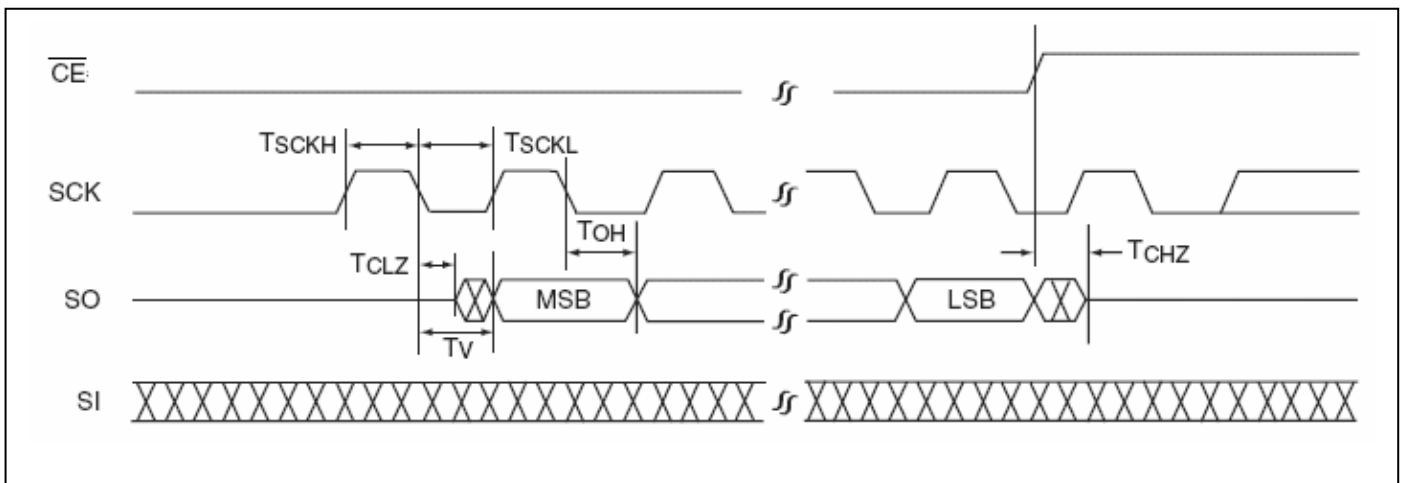

Figure 31: Serial Output Timing Diagram

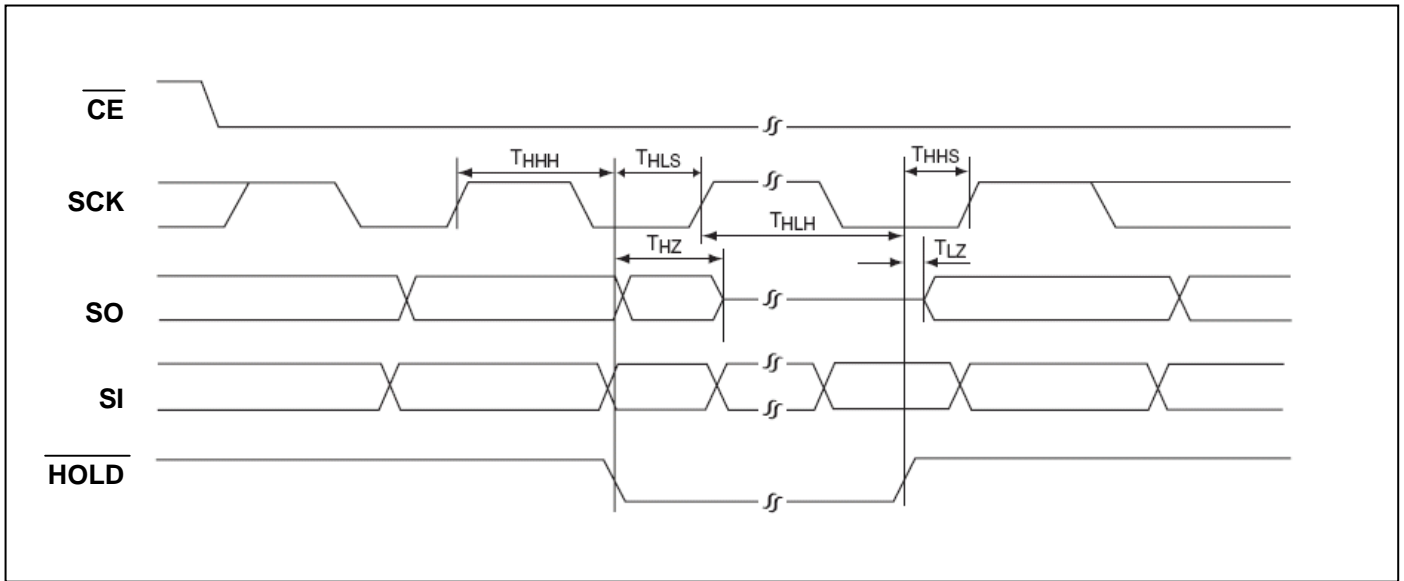

Figure 32: HOLD Timing Diagram

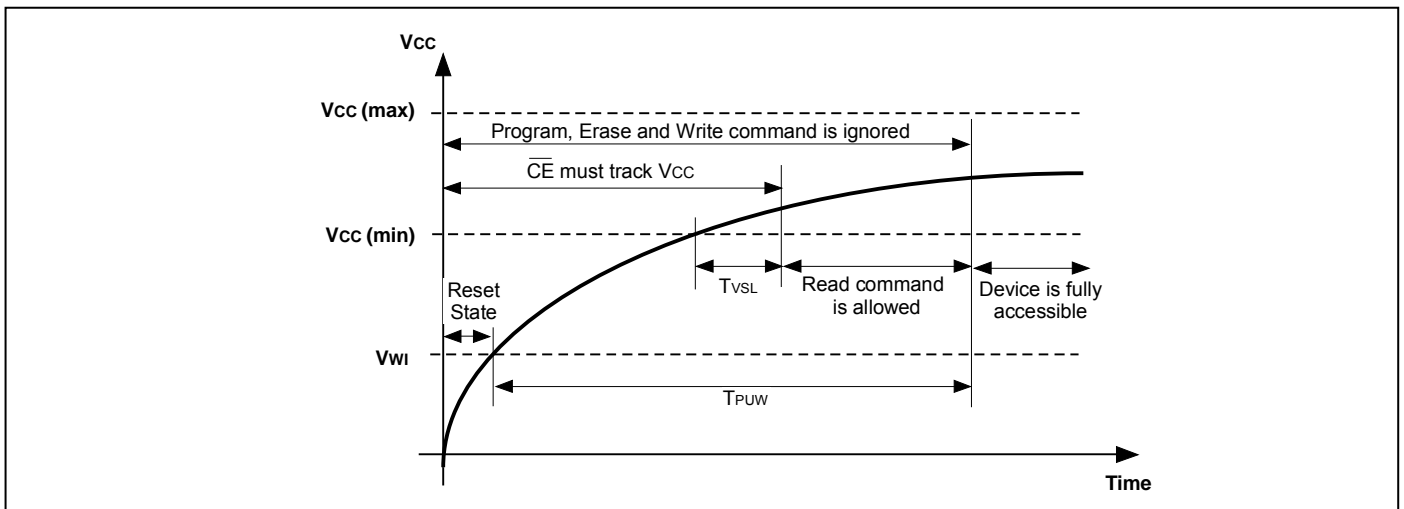

Figure 33: Power-Up Timing Diagram

Table 16: Power-Up Timing and VWI Threshold

Parameter	Symbol	Min.	Max.	Unit
$V_{CC}(\text{min})$ to \overline{CE} low	T_{VSL}	10		us
Time Delay before Write instruction	T_{PUW}		10	ms
Write Inhibit Threshold Voltage	V_{WI}	1	2	V

Note: These parameters are characterized only.

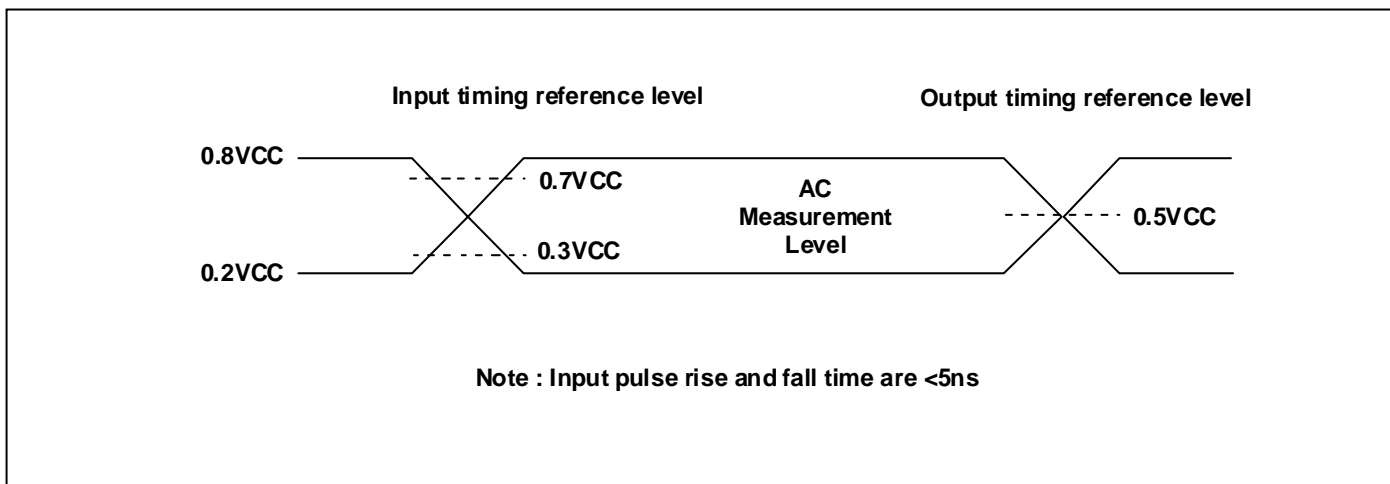

Figure 34: AC Input/Output Reference Waveforms

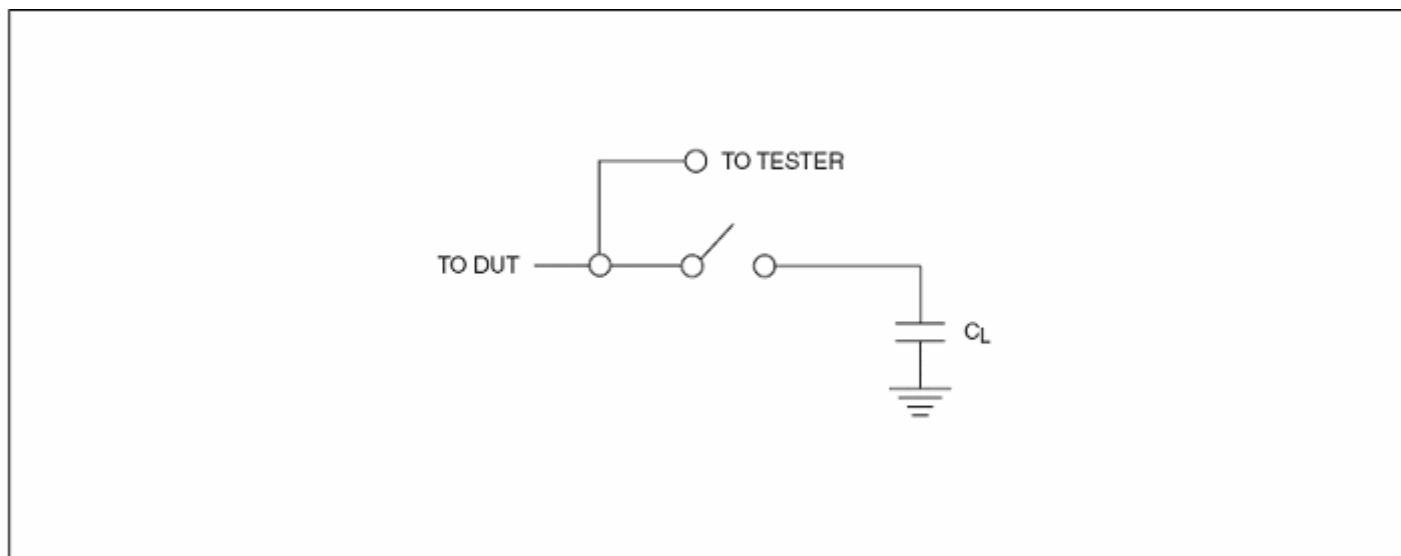
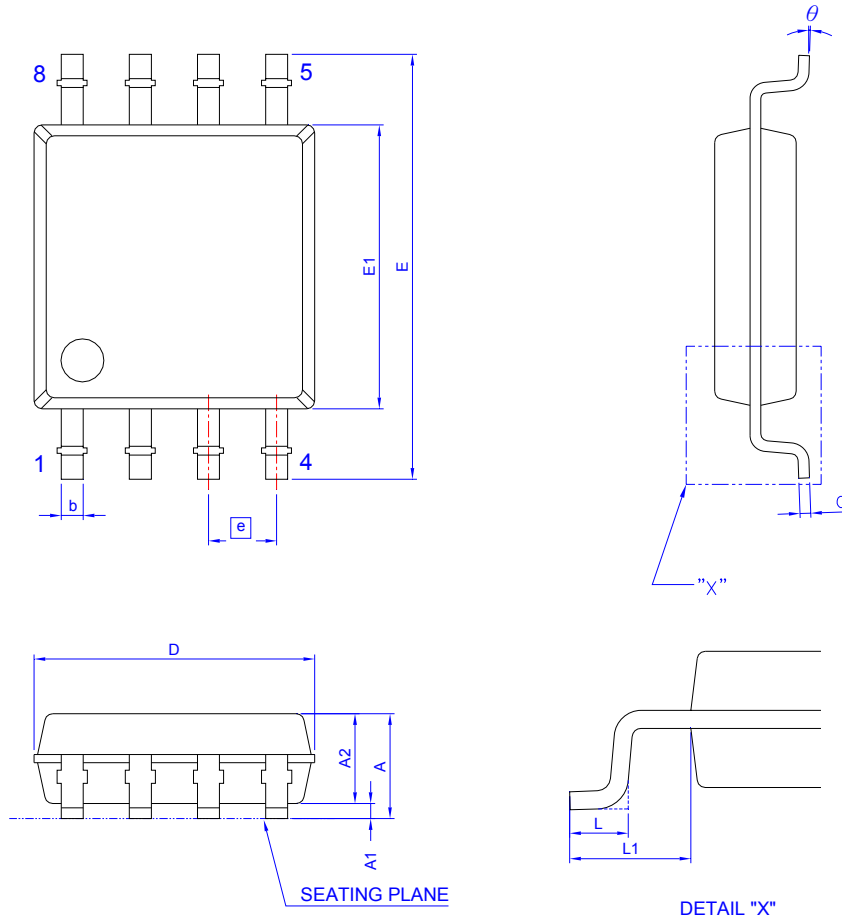

Figure 35: A Test Load Example

PACKING DIMENSIONS

8-LEAD SOIC 200 mil (official name – 209 mil)



Symbol	Dimension in mm			Dimension in inch			Symbol	Dimension in mm			Dimension in inch		
	Min	Norm	Max	Min	Norm	Max		Min	Norm	Max	Min	Norm	Max
A	---	---	2.16	---	---	0.085	E	7.70	7.90	8.10	0.303	0.311	0.319
A ₁	0.05	0.15	0.25	0.002	0.006	0.010	E ₁	5.18	5.28	5.38	0.204	0.208	0.212
A ₂	1.70	1.80	1.91	0.067	0.071	0.075	L	0.50	0.65	0.80	0.020	0.026	0.032
b	0.36	0.41	0.51	0.014	0.016	0.020	e	1.27 BSC			0.050 BSC		
c	0.19	0.20	0.25	0.007	0.008	0.010	L ₁	1.27	1.37	1.47	0.050	0.054	0.058
D	5.13	5.23	5.33	0.202	0.206	0.210	θ	0°	---	8°	0°	---	8°

Controlling dimension : millimeter

PACKING DIMENSIONS
16-LEAD SOIC (300 mil)

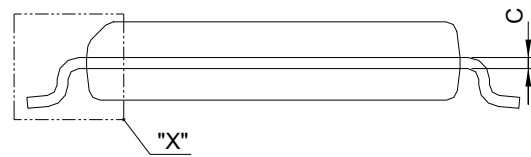
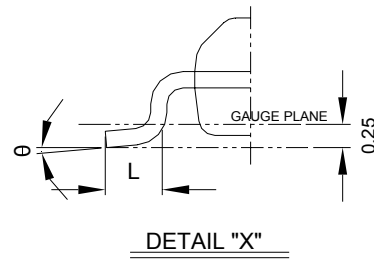
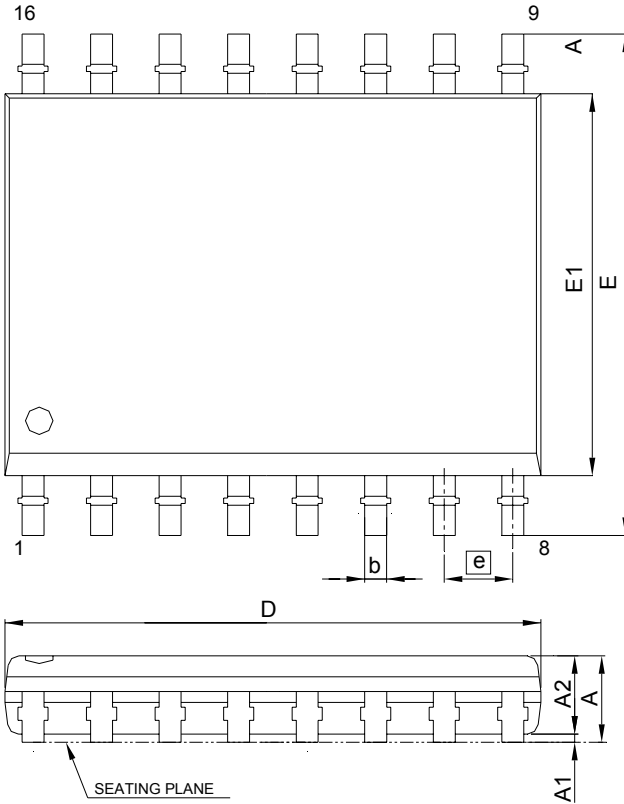

Symbol	Dimension in mm			Dimension in inch			Symbol	Dimension in mm			Dimension in inch		
	Min	Norm	Max	Min	Norm	Max		Min	Norm	Max	Min	Norm	Max
A	---	---	2.65	---	---	0.104	E	10.30 BSC			0.406 BSC		
A ₁	0.1	---	0.3	0.004	---	0.012	E ₁	7.50 BSC			0.295 BSC		
A ₂	2.05	---	---	0.081	---	---	L	0.40	---	1.27	0.016	---	0.050
b	0.31	---	0.51	0.012	---	0.020	e	1.27 BSC			0.050 BSC		
c	0.20	---	0.33	0.008	---	0.013	θ	0°	---	8°	0°	---	8°
D	10.10	10.30	10.50	0.400	0.406	0.413							

Controlling dimension : millimeter

Revision History

Revision	Date	Description
0.1	2008.11.21	Original
0.2	2009.01.09	1. Modify the specification of T_{CE} 2. Modify headline
1.0	2009.03.16	1. Add Dual SPI instructions 2. Modify the memory type of JEDEC Read-ID data from 40H to 20H 3. Delete the rating of Temperature Under Bias
1.1	2009.07.20	1. Modify the size of OTP security sector 2. Correct WRSR of Device Operation Instruction table 3. Modify the description of OTP mode
1.2	2009.11.12	1. Modify the specification of T_{VSL} 2. Delete $T_{PU-READ}$ & $T_{PU-WRITE}$

Important Notice

All rights reserved.

No part of this document may be reproduced or duplicated in any form or by any means without the prior permission of ESMT.

The contents contained in this document are believed to be accurate at the time of publication. ESMT assumes no responsibility for any error in this document, and reserves the right to change the products or specification in this document without notice.

The information contained herein is presented only as a guide or examples for the application of our products. No responsibility is assumed by ESMT for any infringement of patents, copyrights, or other intellectual property rights of third parties which may result from its use. No license, either express, implied or otherwise, is granted under any patents, copyrights or other intellectual property rights of ESMT or others.

Any semiconductor devices may have inherently a certain rate of failure. To minimize risks associated with customer's application, adequate design and operating safeguards against injury, damage, or loss from such failure, should be provided by the customer when making application designs.

ESMT's products are not authorized for use in critical applications such as, but not limited to, life support devices or system, where failure or abnormal operation may directly affect human lives or cause physical injury or property damage. If products described here are to be used for such kinds of application, purchaser must do its own quality assurance testing appropriate to such applications.