

Flash**4 Gbit (512M x 8)**
3.3V NAND Flash Memory**FEATURES**

- Voltage Supply: 3.3V (2.7V ~ 3.6V)
- Organization
 - Memory Cell Array: (512M + 16M) x 8bit
 - Data Register: (2K + 64) x 8bit
- Automatic Program and Erase
 - Page Program: (2K + 64) bytes
 - Block Erase: (128K + 4K) bytes
- Page Read Operation
 - Page Size: (2K + 64) bytes
 - Random Read: 25us (Max.)
 - Serial Access: 25ns (Min.)
- Memory Cell: 1bit/Memory Cell
- Fast Write Cycle Time
 - Program time: 350us (Typ.)
 - Block Erase time: 3.5ms (Typ.)
- Command/Address/Data Multiplexed I/O Port
- Hardware Data Protection
 - Program/Erase Lockout During Power Transitions
- Reliable CMOS Floating Gate Technology
 - ECC Requirement: 4bit/512Byte
 - Endurance: 60K Program/Erase cycles
 - Data Retention: 10 years
- Command Register Operation
- Automatic Page 0 Read at Power-Up Option
 - Boot from NAND support
 - Automatic Memory Download
- NOP: 4 cycles
- Cache Program Operation for High Performance Program
- Cache Read Operation
- Copy-Back Operation
 - EDO mode
 - OTP Operation
 - Two-Plane Operation
- Bad-Block-Protect

ORDERING INFORMATION

Product ID	Speed	Package	Comments
Automotive Range (V): -40°C to +85°C			
F59L4G81A -25TVG	25 ns	48 pin TSOP1	Pb-free
Automotive Range (VA): -40°C to +105°C			
F59L4G81A -25TVAG	25 ns	48 pin TSOP1	Pb-free

GENERAL DESCRIPTION

The device is a 512Mx8bit with spare 16Mx8bit capacity. The device is offered in 3.3V V_{CC} Power Supply. Its NAND cell provides the most cost-effective solution for the solid state mass storage market. The memory is divided into blocks that can be erased independently so it is possible to preserve valid data while old data is erased.

The device contains 4096 blocks, composed by 64 pages consisting in two NAND structures of 32 series connected Flash cells. A program operation allows to write the 2112-Word page in typical 350us and an erase operation can be performed in typical 3.5ms on a 128K-Byte for X8 device block.

Data in the page mode can be read out at 25ns cycle time per Word. The I/O pins serve as the ports for address and command

inputs as well as data input/output. The copy back function allows the optimization of defective blocks management: when a page program operation fails the data can be directly programmed in another page inside the same array section without the time consuming serial data insertion phase. The cache program feature allows the data insertion in the cache register while the data register is copied into the Flash array. This pipelined program operation improves the program throughput when long files are written inside the memory. A cache read feature is also implemented. This feature allows to dramatically improving the read throughput when consecutive pages have to be streamed out. This device includes extra feature: Automatic Read at Power Up.

PIN CONFIGURATION (TOP VIEW)

(TSOPI 48L, 12mm X 20mm Body, 0.5mm Pin Pitch)



Pin Description

Symbol	Pin Name	Functions
I/O0~I/O7	Data Inputs / Outputs	The I/O pins are used to input command, address and data, and to output data during read operations. The I/O pins float to Hi-Z when the chip is deselected or when the outputs are disabled.
CLE	Command Latch Enable	The CLE input controls the activating path for commands sent to the internal command register. Commands are latched into the command register through the I/O ports on the rising edge of the \overline{WE} signal with CLE high.
ALE	Address Latch Enable	The ALE input controls the activating path for addresses sent to the internal address registers. Addresses are latched into the address register through the I/O ports on the rising edge of \overline{WE} with ALE high.
\overline{CE}	Chip Enable	The \overline{CE} input is the device selection control. When the device is in the Busy state, \overline{CE} high is ignored, and the device does not return to standby mode in program or erase operation. Regarding \overline{CE} control during read operation, refer to 'Page read' section of Device operation.
\overline{RE}	Read Enable	The \overline{RE} input is the serial data-out control, and when it is active low, it drives the data onto the I/O bus. Data is valid t_{REA} after the falling edge of \overline{RE} which also increments the internal column address counter by one.
\overline{WE}	Write Enable	The \overline{WE} input controls writes to the I/O port. Commands, address and data are latched on the rising edge of the \overline{WE} pulse.
\overline{WP}	Write Protect	The \overline{WP} pin provides inadvertent program/erase protection during power transitions. The internal high voltage generator is reset when the \overline{WP} pin is active low.
R/ \overline{B}	Ready / Busy Output	The R/ \overline{B} output indicates the status of the device operation. When low, it indicates that a program, erase or random read operation is in process and returns to high state upon completion. It is an open drain output and does not float to Hi-Z condition when the chip is deselected or when outputs are disabled.
V_{CC}	Power	V_{CC} is the power supply for device.
V_{SS}	Ground	
NC	No Connection	Lead is not internally connected.

Note: Connect all V_{CC} and V_{SS} pins of each device to common power supply outputs. Do not leave V_{CC} or V_{SS} disconnected.

BLOCK DIAGRAM

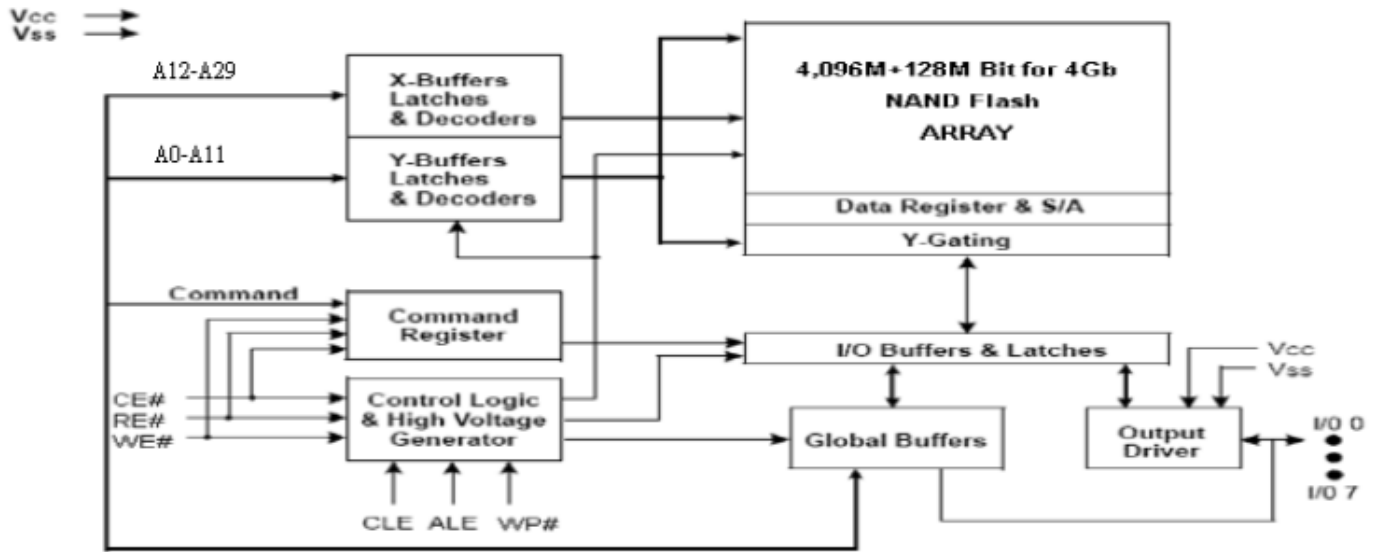

ARRAY ORGANIZATION

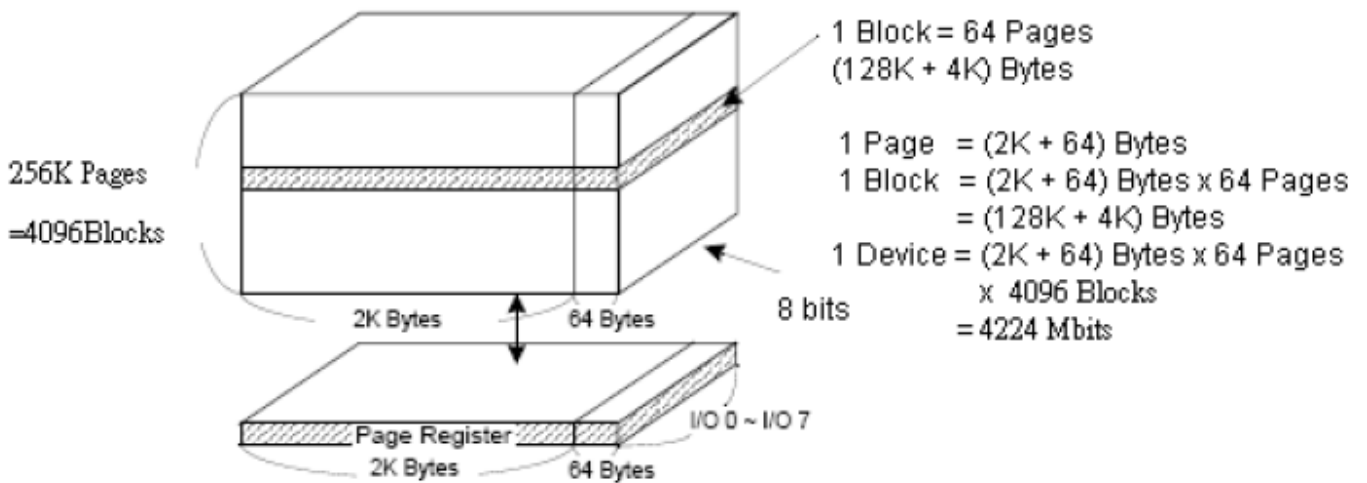

Array Address

	I/O0	I/O1	I/O2	I/O3	I/O4	I/O5	I/O6	I/O7	Address
1st cycle	A0	A1	A2	A3	A4	A5	A6	A7	Column Address
2nd cycle	A8	A9	A10	A11	L*	L*	L*	L*	Column Address
3rd cycle	A12	A13	A14	A15	A16	A17	A18	A19	Row Address
4th cycle	A20	A21	A22	A23	A24	A25	A26	A27	Row Address
5th cycle	A28	A29	L*	L*	L*	L*	L*	L*	Row Address

NOTE:

Column Address: Starting Address of the Register.

*L must be set to "Low".

* The device ignores any additional input of address cycles than required.
A18 is for Plane Address setting.

Product Introduction

The device is a 4,224Mbit memory organized as 256K rows (pages) by 2,112x8 columns. Spare 64x8 columns are located from column address of 2,048~2,111. A 2,112-byte data register is connected to memory cell arrays accommodating data transfer between the I/O buffers and memory during page read and page program operations. The program and read operations are executed on a page basis, while the erase operation is executed on a block basis. The memory array consists of 4096 separately erasable 128K-byte blocks. It indicates that the bit-by-bit erase operation is prohibited on the device.

The device has addresses multiplexed into 8 I/Os. This scheme dramatically reduces pin counts and allows system upgrades to future densities by maintaining consistency in system board design. Command, address and data are all written through I/O's by bringing \overline{WE} to low while \overline{CE} is low. Those are latched on the rising edge of \overline{WE} . Command Latch Enable (CLE) and Address Latch Enable (ALE) are used to multiplex command and address respectively, via the I/O pins. Some commands require one bus cycle. For example, Reset Command, Status Read Command, etc require just one cycle bus. Some other commands, like page read and block erase and page program, require two cycles: one cycle for setup and the other cycle for execution.

In addition to the enhanced architecture and interface, the device incorporates copy-back program feature from one page to another page without need for transporting the data to and from the external buffer memory.

Command Set

Function	1st Cycle	2nd Cycle	Acceptable Command during Busy
Read	00h	30h	
Read for Copy Back	00h	35h	
Read ID	90h	-	
Reset	FFh	-	○
Page Program	80h	10h	
Copy-Back Program	85h	10h	
Block Erase	60h	D0h	
Random Data Input ⁽¹⁾	85h	-	
Random Data Output ⁽¹⁾	05h	E0h	
Read Status	70h	-	○
Read Status 2	F1h	-	○
Two-Plane Read ⁽³⁾	60h-60h	30h	
Two-Plane Read for Copy-Back	60h-60h	35h	
Two-Plane Random Data Output ⁽¹⁾⁽³⁾	00h-05h	E0h	
Two-Plane Page Program ⁽²⁾	80h-11h	81h-10h	
Two-Plane Copy-Back Program ⁽²⁾	85h-11h	81h-10h	
Two-Plane Block Erase	60h-60h	D0h	
Cache Program	80h	15h	
Cache Read	31h	-	
Read Start For Last Page Cache Read	3Fh	-	
Two-Plane Cache Read ⁽³⁾	60h-60h	33h	
Two-Plane Cache Program ⁽²⁾	80h-11h	81h-15h	

NOTE:

1. Random Data Input/Output can be executed in a page.
2. Any command between 11h and 80h/81h/85h is prohibited except 70h/F1h and FFh.
3. Two-Plane Random Data Output must be used after Two-Plane Read operation or Two-Plane Cache Read operation.

ABSOLUTE MAXIMUM RATINGS

Parameter	Symbol	Rating	Unit
Voltage on any pin relative to V _{SS}	V _{CC}	-0.6 to +4.6	V
	V _{IN}	-0.6 to +4.6	
	V _{I/O}	-0.6 to V _{CC} + 0.3 (< 4.6V)	
Operating ambient temperature	T _A (V grade)	-40 ~+85	°C
	T _A (VA grade)	-40 ~+105	°C
Temperature Under Bias	T _{BIAS}	-40 to +125	°C
Storage Temperature	T _{STG}	-65 to +150	°C
Short Circuit Current	I _{OS}	5	mA

NOTE:

Permanent device damage may occur if ABSOLUTE MAXIMUM RATINGS are exceeded. Functional operation should be restricted to the conditions as detailed in the operational sections of this data sheet. Exposure to absolute maximum rating conditions for extended periods may affect reliability.

RECOMMENDED OPERATING CONDITIONS

(Voltage reference to GND, T_A = -40 to +85°C (V grade) / -40 to +105°C (VA grade))

Parameter	Symbol	Min.	Typ.	Max.	Unit
Supply Voltage	V _{CC}	2.7	3.3	3.6	V
Supply Voltage	V _{SS}	0	0	0	V

DC AND OPERATION CHARACTERISTICS

(Recommended operating conditions otherwise noted)

Parameter		Symbol	Test Conditions	Min.	Typ.	Max.	Unit
Operating Current	Page Read with Serial Access	I _{CC1}	t _{RC} =25ns, $\overline{CE}=V_{IL}$, I _{OUT} =0mA	-	15	30	mA
	Program	I _{CC2}	-	-	15	30	
	Erase	I _{CC3}	-	-	15	30	
Stand-by Current (TTL)		I _{SB1}	$\overline{CE}=V_{IH}$, $\overline{WP}=0V/V_{CC}$	-	-	1	mA
Stand-by Current (CMOS)		I _{SB2}	$\overline{CE}=V_{CC}-0.2$, $\overline{WP}=0V/V_{CC}$	-	10	50	uA
Input Leakage Current		I _{LI}	V _{IN} =0 to V _{CC} (max)	-	-	±10	uA
Output Leakage Current		I _{LO}	V _{OUT} =0 to V _{CC} (max)	-	-	±10	uA
Input High Voltage		V _{IH} ⁽¹⁾	-	0.8 x V _{CC}	-	V _{CC} + 0.3	V
Input Low Voltage, All inputs		V _{IL} ⁽¹⁾	-	-0.3	-	0.2 x V _{CC}	V
Output High Voltage Level		V _{OH}	I _{OH} =-400uA	2.4	-	-	V
Output Low Voltage Level		V _{OL}	I _{OL} =2.1mA	-	-	0.4	V
Output Low Current (R/ \overline{B})		I _{OL} (R/ \overline{B})	V _{OL} =0.4V	8	10	-	mA

NOTE:

- V_{IL} can undershoot to -0.4V and V_{IH} can overshoot to V_{CC} + 0.4V for durations of 20 ns or less.
- Typical value are measured at V_{CC}=3.3V, T_A=25°C. Not 100% tested.

VALID BLOCK

Symbol	Min.	Typ.	Max.	Unit
N _{VB}	4,016	-	4,096	Block

NOTE:

1. The device may include initial invalid blocks when first shipped. Additional invalid blocks may develop while being used. The number of valid blocks is presented with both cases of invalid blocks considered. Invalid blocks are defined as blocks that contain one or more bad bits which cause status failure during program and erase operation. Do not erase or program factory-marked bad blocks. Refer to the attached technical notes for appropriate management of initial invalid blocks.
2. The 1st block, which is placed on 00h block address, is guaranteed to be a valid block at the time of shipment and is guaranteed to be a valid block up to 1K program/erase cycles with 4bit/512Byte ECC.

AC TEST CONDITION

($T_A = -40$ to $+85^\circ\text{C}$ (V grade) / -40 to $+105^\circ\text{C}$ (VA grade), $V_{CC} = 2.7\text{V} \sim 3.6\text{V}$, unless otherwise noted)

Parameter	Condition
Input Pulse Levels	0V to V_{CC}
Input Rise and Fall Times	5 ns
Input and Output Timing Levels	$V_{CC} / 2$
Output Load	1 TTL Gate and $C_L = 50\text{pF}$

NOTE: Refer to Read/ $\overline{\text{Busy}}$ section, $R/\overline{\text{B}}$ output's Busy to Ready time is decided by the pull-up resistor (R_p) tied to the $R/\overline{\text{B}}$ pin.

CAPACITANCE

($T_A = 25^\circ\text{C}$, $V_{CC} = 3.3\text{V}$, $f = 1.0\text{MHz}$)

Item	Symbol	Test Condition	Min.	Max.	Unit
Input / Output Capacitance	$C_{I/O}$	$V_{IL} = 0\text{V}$	-	8	pF
Input Capacitance	C_{IN}	$V_{IN} = 0\text{V}$	-	8	pF

NOTE: Capacitance is periodically sampled and not 100% tested.

MODE SELECTION

CLE	ALE	$\overline{\text{CE}}$	$\overline{\text{WE}}$	$\overline{\text{RE}}$	$\overline{\text{WP}}$	Mode	
H	L	L		H	X	Read Mode	Command Input
L	H	L		H	X		Address Input (5 clock)
H	L	L		H	H	Write Mode	Command Input
L	H	L		H	H		Address Input (5 clock)
L	L	L		H	H	Data Input	
L	L	L	H		X	Data Output	
X	X	X	X	H	X	During Read (Busy)	
X	X	X	X	X	H	During Program (Busy)	
X	X	X	X	X	H	During Erase (Busy)	
X	$X^{(1)}$	X	X	X	L	Write Protect	
X	X	H	X	X	$0\text{V}/V_{CC}^{(2)}$	Stand-by	

NOTE:

1. X can be V_{IL} or V_{IH} .
2. $\overline{\text{WP}}$ should be biased to CMOS high or CMOS low for standby.

Program / Erase Characteristics

($T_A = -40$ to $+85^\circ\text{C}$ (V grade) / -40 to $+105^\circ\text{C}$ (VA grade), $V_{CC} = 2.7\text{V} \sim 3.6\text{V}$)

Parameter	Symbol	Min.	Typ.	Max.	Unit
Average Program Time	t_{PROG}	-	450	950	us
Dummy Busy Time for Cache Operation	t_{CBSY}	-	3	950	us
Number of Partial Program Cycles in the Same Page	N_{OP}	-	-	4	Cycle
Block Erase Time	t_{BERS}	-	3.5	10	ms
Dummy Busy Time for Two-Plane Page Program	t_{DBSY}		0.5	1	us

NOTE:

1. Typical program time is defined as the time within which more than 50% of the whole pages are programmed at 3.3V V_{CC} and 25°C temperature.
2. t_{PROG} is the average program time of all pages. Users should be noted that the program time variation from page to page is possible.
3. t_{CBSY} max. time depends on timing between internal program completion and data-in.

AC Timing Characteristics for Command / Address / Data Input

Parameter	Symbol	Min.	Max.	Unit
CLE Setup Time	$t_{\text{CLS}}^{(1)}$	12	-	ns
CLE Hold Time	t_{CLH}	5	-	ns
$\overline{\text{CE}}$ Setup Time	$t_{\text{CS}}^{(1)}$	20	-	ns
$\overline{\text{CE}}$ Hold Time	t_{CH}	5	-	ns
$\overline{\text{WE}}$ Pulse Width	t_{WP}	12	-	ns
ALE Setup Time	$t_{\text{ALS}}^{(1)}$	12	-	ns
ALE Hold Time	t_{ALH}	5	-	ns
Data Setup Time	$t_{\text{DS}}^{(1)}$	12	-	ns
Data Hold Time	t_{DH}	5	-	ns
Write Cycle Time	t_{WC}	25	-	ns
$\overline{\text{WE}}$ High Hold Time	t_{WH}	10	-	ns
Address to Data Loading Time	$t_{\text{ADL}}^{(2)}$	$70^{(2)}$	-	ns

NOTE:

1. The transition of the corresponding control pins must occur only once while $\overline{\text{WE}}$ is held low.
2. t_{ADL} is the time from the $\overline{\text{WE}}$ rising edge of final address cycle to the $\overline{\text{WE}}$ rising edge of first data cycle.

AC Characteristics for Operation

Parameter	Symbol	Min.	Max.	Unit	
Data Transfer from Cell to Register	t_R	-	30	us	
ALE to \overline{RE} Delay	t_{AR}	10	-	ns	
CLE to \overline{RE} Delay	t_{CLR}	10	-	ns	
Ready to \overline{RE} Low	t_{RR}	20	-	ns	
\overline{RE} Pulse Width	t_{RP}	12	-	ns	
\overline{WE} High to Busy	t_{WB}	-	100	ns	
\overline{WP} Low to \overline{WE} Low (disable mode)	t_{WW}	100	-	ns	
\overline{WP} High to \overline{WE} Low (enable mode)					
Read Cycle Time	t_{RC}	25	-	ns	
\overline{RE} Access Time	t_{REA}	-	20	ns	
\overline{CE} Access Time	t_{CEA}	-	25	ns	
\overline{RE} High to Output Hi-Z	t_{RHZ}	-	100	ns	
\overline{CE} High to Output Hi-Z	t_{CHZ}	-	30	ns	
\overline{CE} High to ALE or CLE Don't Care	t_{CSD}	0	-	ns	
\overline{RE} High to Output Hold	t_{RHOH}	15	-	ns	
\overline{RE} Low to Output Hold	t_{RLOH}	5	-	ns	
\overline{CE} High to Output Hold	t_{COH}	15	-	ns	
\overline{RE} High Hold Time	t_{REH}	10	-	ns	
Output Hi-Z to \overline{RE} Low	t_{IR}	0	-	ns	
\overline{RE} High to \overline{WE} Low	t_{RHW}	100	-	ns	
\overline{WE} High to \overline{RE} Low	t_{WHR}	60	-	ns	
Device Resetting Time during ...	Read	t_{RST}	-	5 ⁽¹⁾	us
	Program		-	10 ⁽¹⁾	us
	Erase		-	500	us
	Ready		-	5 ⁽¹⁾	us
Cache Busy in Read Cache (following 31h and 3Fh)	t_{DCBSYR}	-	30	us	

NOTE: 1. If reset command (FFh) is written at Ready state, the device goes into Busy for maximum 5us.

NAND Flash Technical Notes

Mask Out Initial Invalid Block(s)

Initial invalid blocks are defined as blocks that contain one or more initial invalid bits whose reliability is not guaranteed by ESMT. The information regarding the initial invalid block(s) is called the initial invalid block information. Devices with initial invalid block(s) have the same quality level as devices with all valid blocks and have the same AC and DC characteristics. An initial invalid block(s) does not affect the performance of valid block(s) because it is isolated from the bit line and the common source line by a select transistor. The system design must be able to mask out the initial invalid block(s) via address mapping.

The 1st block, which is placed on 00h block address, is guaranteed to be a valid block up to 1K program/erase cycles with 4bit/512Byte ECC.

Identifying Initial Invalid Block(s) and Block Replacement Management

All device locations are erased (FFh) except locations where the initial invalid block(s) information is written prior to shipping. The initial invalid block(s) status is defined by the 1st byte in the spare area. ESMT makes sure that either the 1st or 2nd page of every initial invalid block has non-FFh data at the 1st byte column address in the spare area.

Do not erase or program factory-marked bad blocks. The host controller must be able to recognize the initial invalid block information and to create a corresponding table to manage block replacement upon erase or program error when additional invalid blocks develop with Flash memory usage.

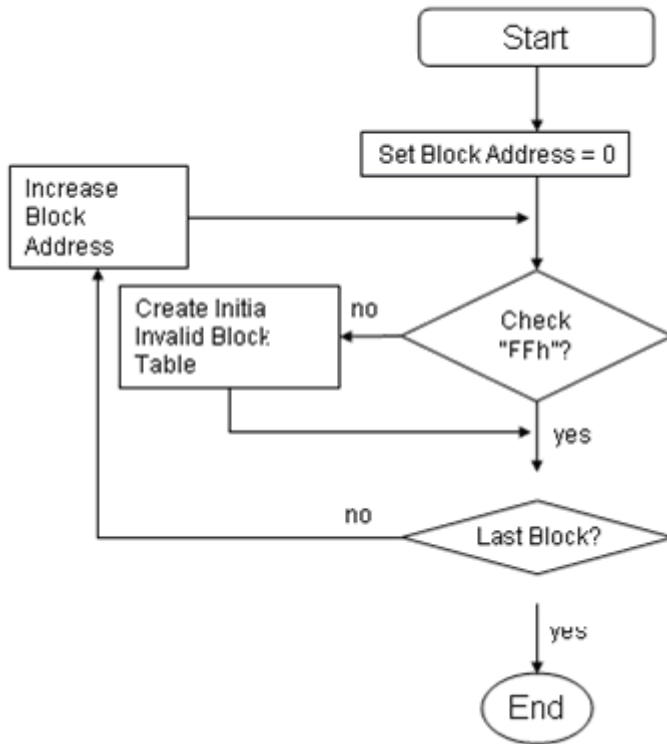

Check "FFh" at the 1st Byte column address in the spare area of the 1st and 2nd page in the block.

```

For (i=0; i<Num_of_LUs; i++)
{
  For (j=0; j<Blocks_Per_LU; j++)
  {
    Defect_Block_Found=False;

    Read_Page(lu=i, block=j, page=0);
    If (Data[column= First_Byte_of_Spare_Area]!=FFh) Defect_Block_Found=True;

    Read_Page(lu=i, block=j, page=1);
    If (Data[column= First_Byte_of_Spare_Area]!=FFh) Defect_Block_Found=True;

    If (Defect_Block_Found) Mark_Block_as_Defective(lu=i, block=j);
  }
}
  
```

Error in Write or Read Operation

Within its lifetime, additional invalid blocks may develop with NAND Flash memory. Refer to the qualification report for the actual data. The following possible failure modes should be considered to implement a highly reliable system. In the case of status read failure after erase or program, block replacement should be done. Because program status fail during a page program does not affect the data of the other pages in the same block, block replacement can be executed with a page-sized buffer by finding an erased empty block and reprogramming the current target data and copying the rest of the replaced block. In case of Read, ECC must be employed. To improve the efficiency of memory space, it is recommended that the read or verification failure due to single bit error be reclaimed by ECC without any block replacement. The additional block failure rate does not include those reclaimed blocks.

Failure Mode		Detection and Countermeasure sequence
Write	Erase failure	Read Status after Erase → Block Replacement
	Program failure	Read Status after Program → Block Replacement
Read	Up to 4 bits failure	Verify ECC → ECC Correction

NOTE: Error Correcting Code → RS Code or BCH Code etc.
Example: 4bit correction / 512 Byte

Program Flow Chart

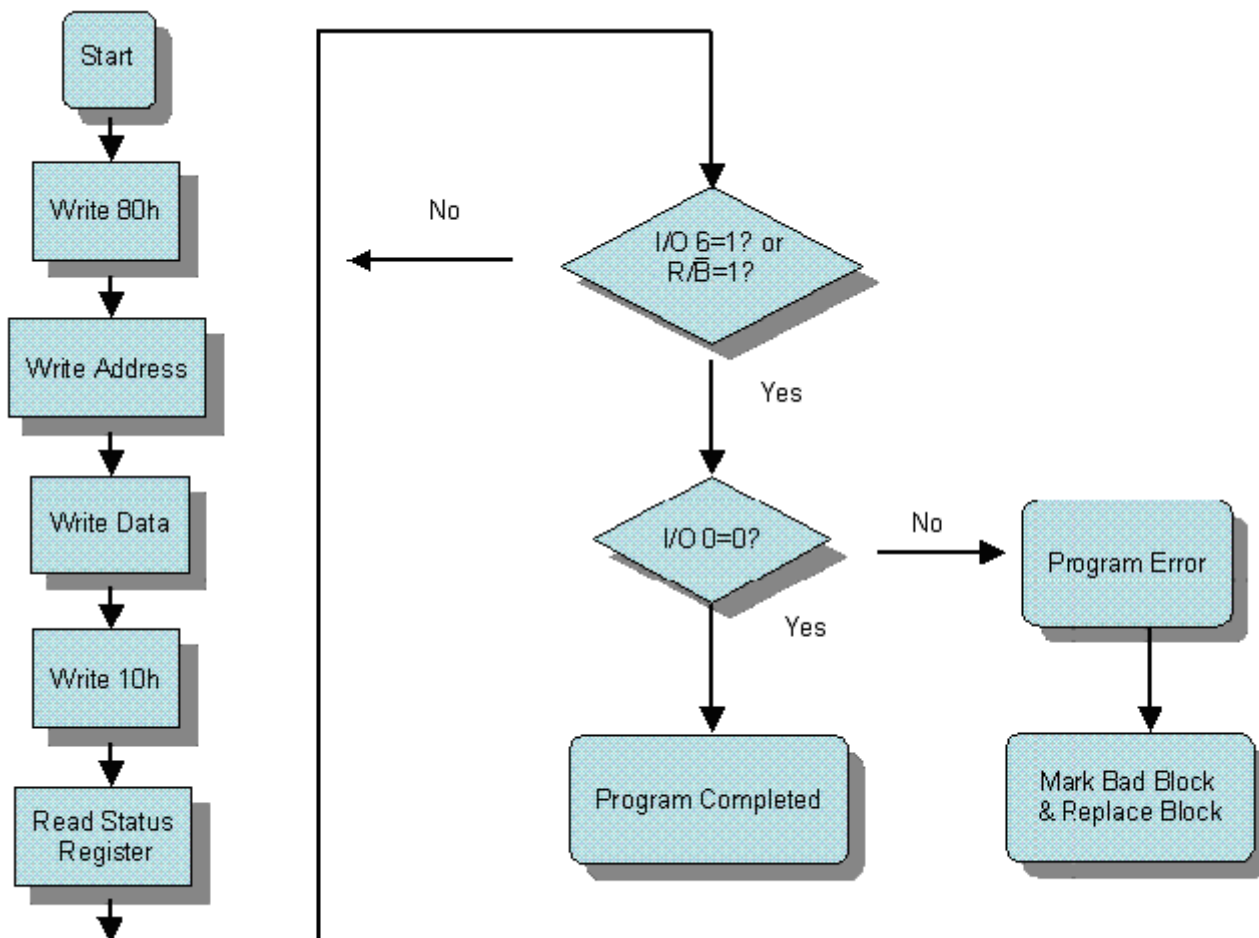

Erase Flow Chart

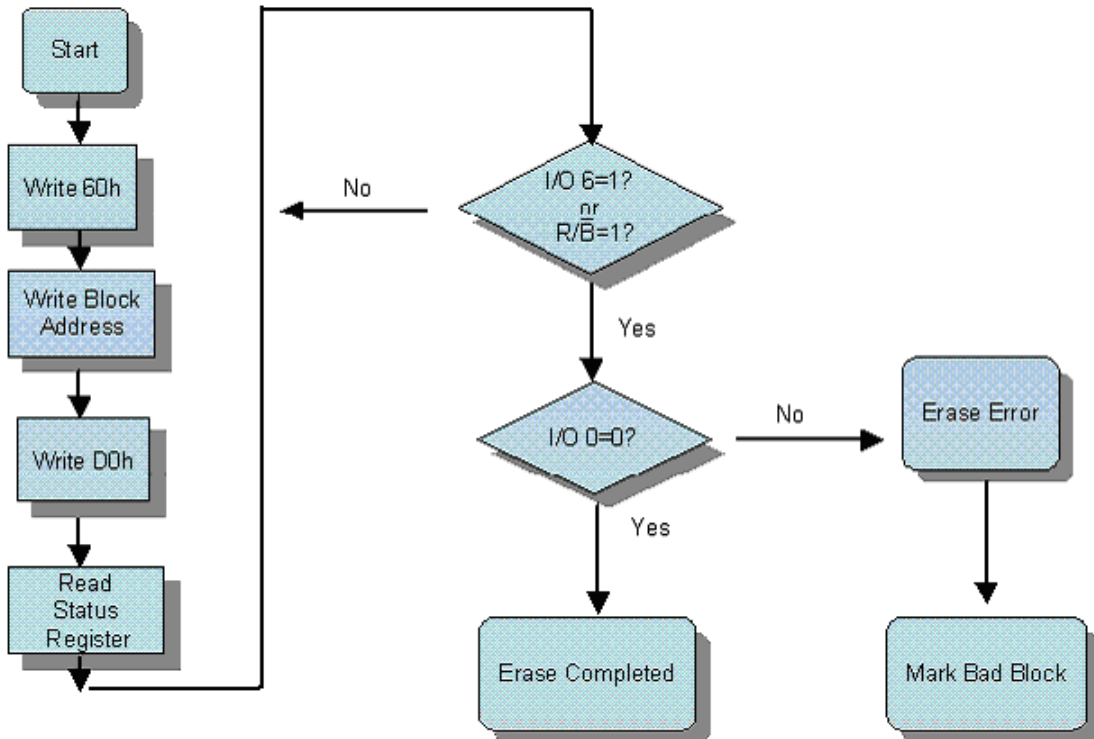

Read Flow Chart

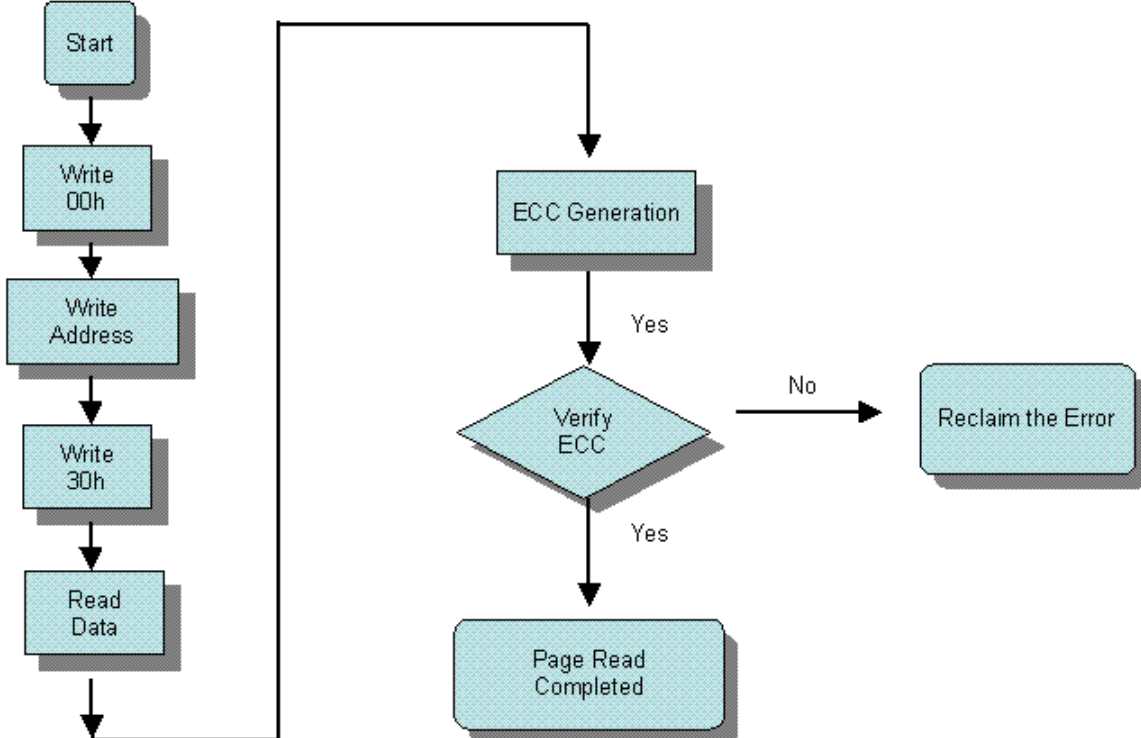

Block Replacement

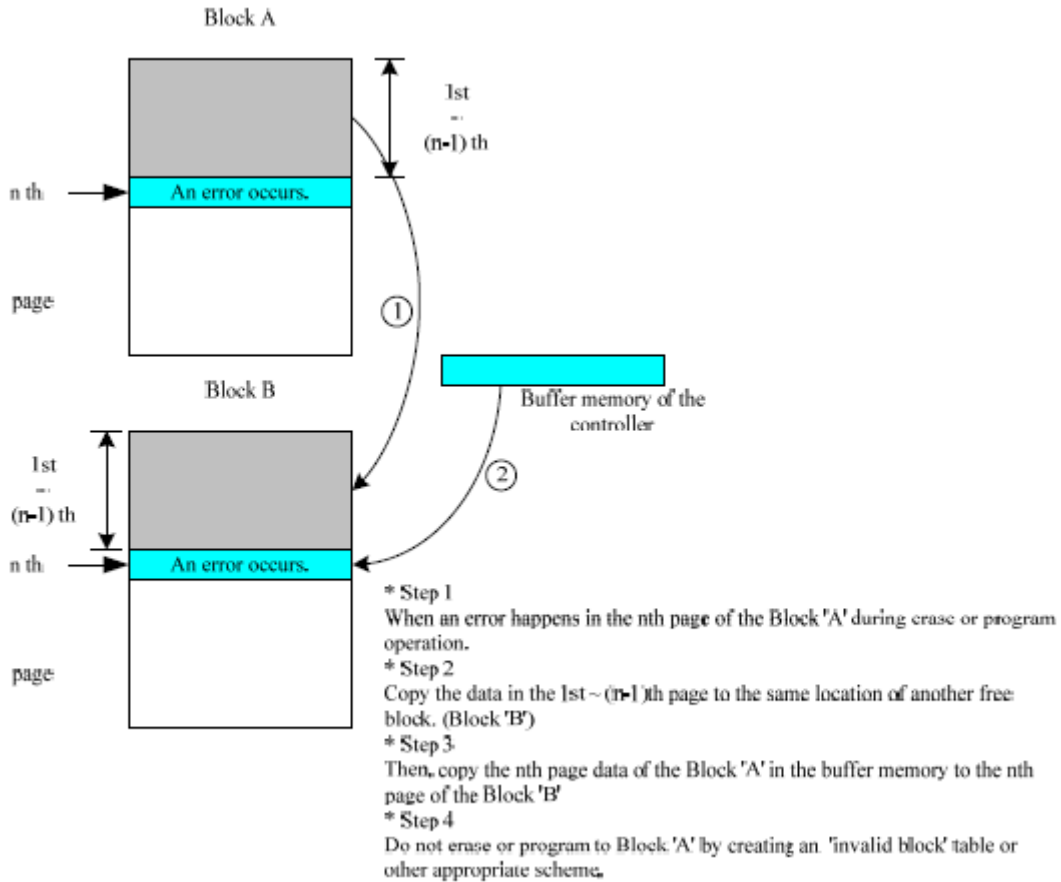

Addressing for program operation

Within a block, the pages must be programmed consecutively from the LSB (Least Significant Bit) page of the block to MSB (Most Significant Bit) pages of the block. Random page address programming is prohibited. In this case, the definition of LSB page is the LSB among the pages to be programmed. Therefore, LSB page doesn't need to be page 0.

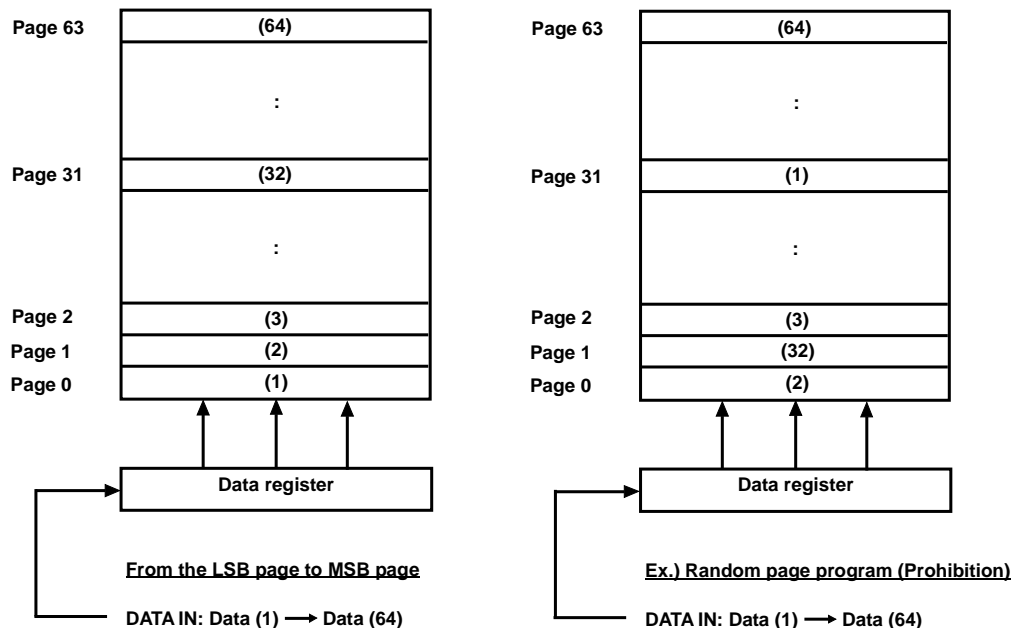

Timing Diagrams

Command Latch Cycle

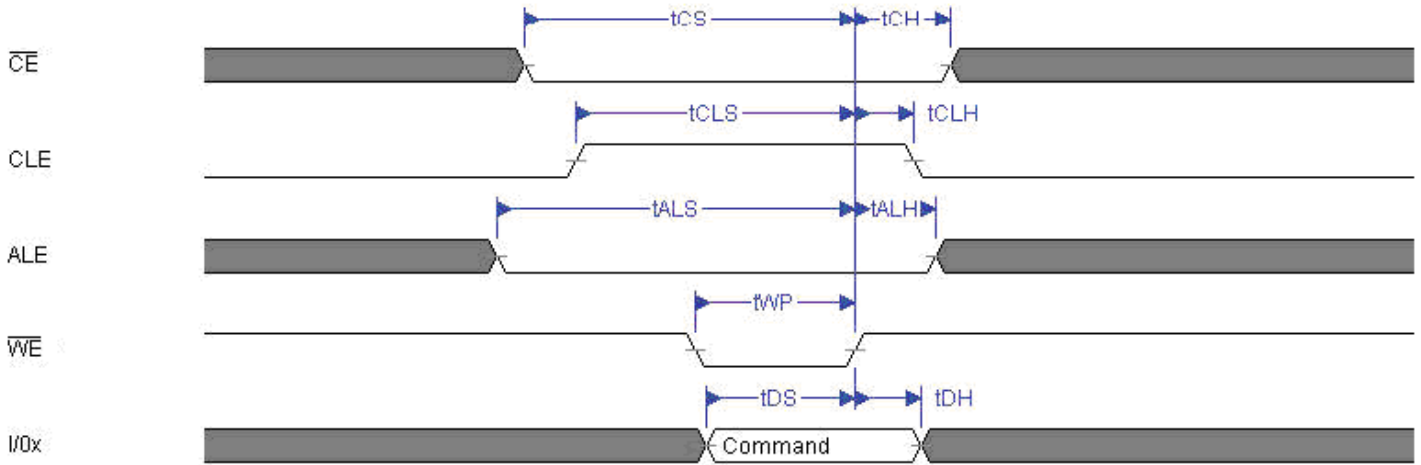

Address Latch Cycle

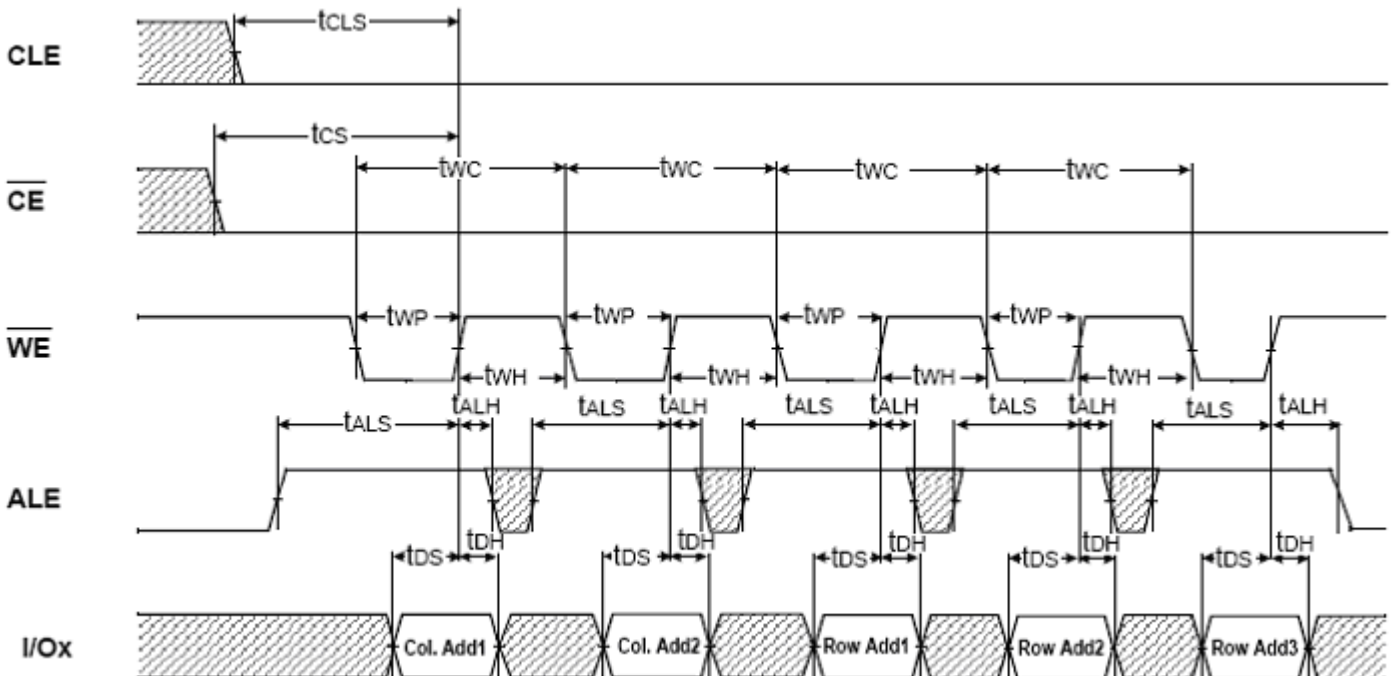

Input Data Latch Cycle

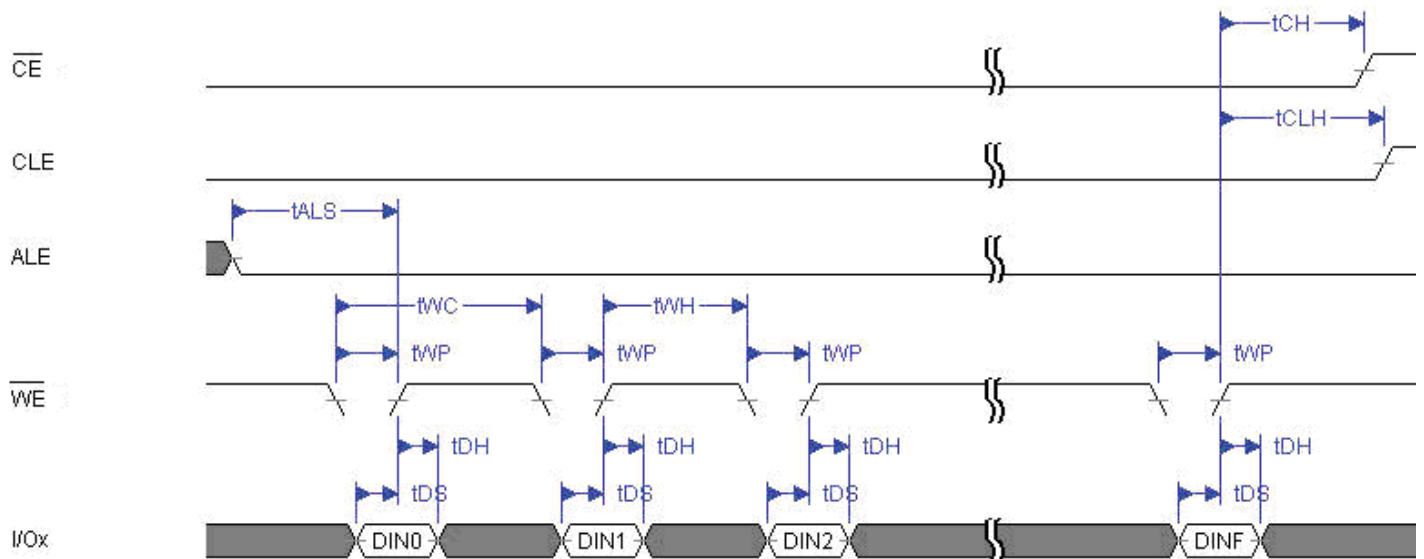

Serial Access Cycle after Read ($CLE = L$, $ALE = L$, $\overline{WE} = H$)

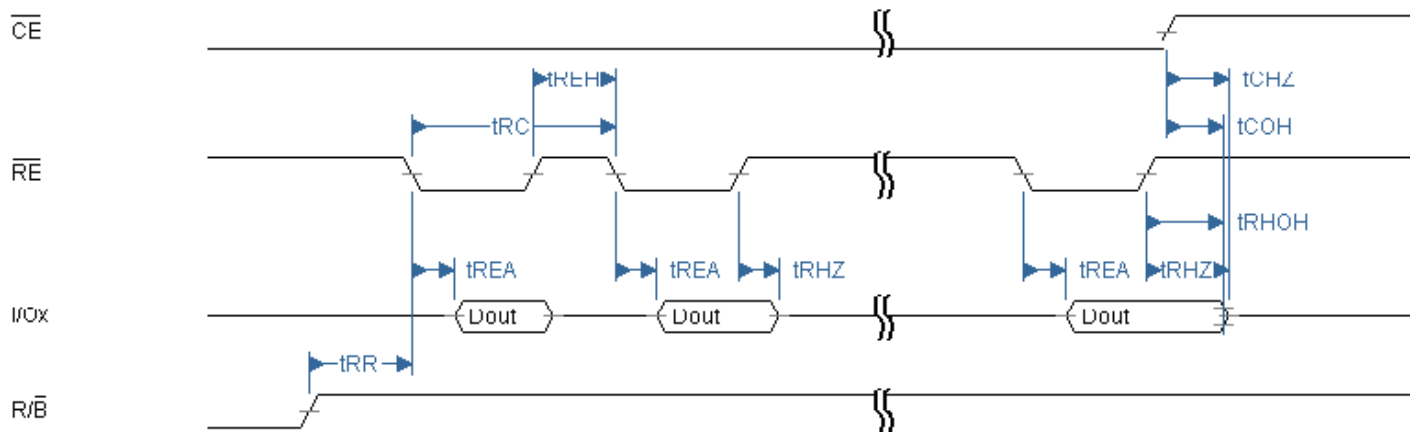

NOTE:

1. Dout transition is measured at $\pm 200\text{mV}$ from steady state voltage at I/O with load.
2. t_{RHOH} starts to be valid when frequency is lower than 33MHz.

Serial Access Cycle after Read (EDO Type CLE = L, ALE = L, \overline{WE} = H)

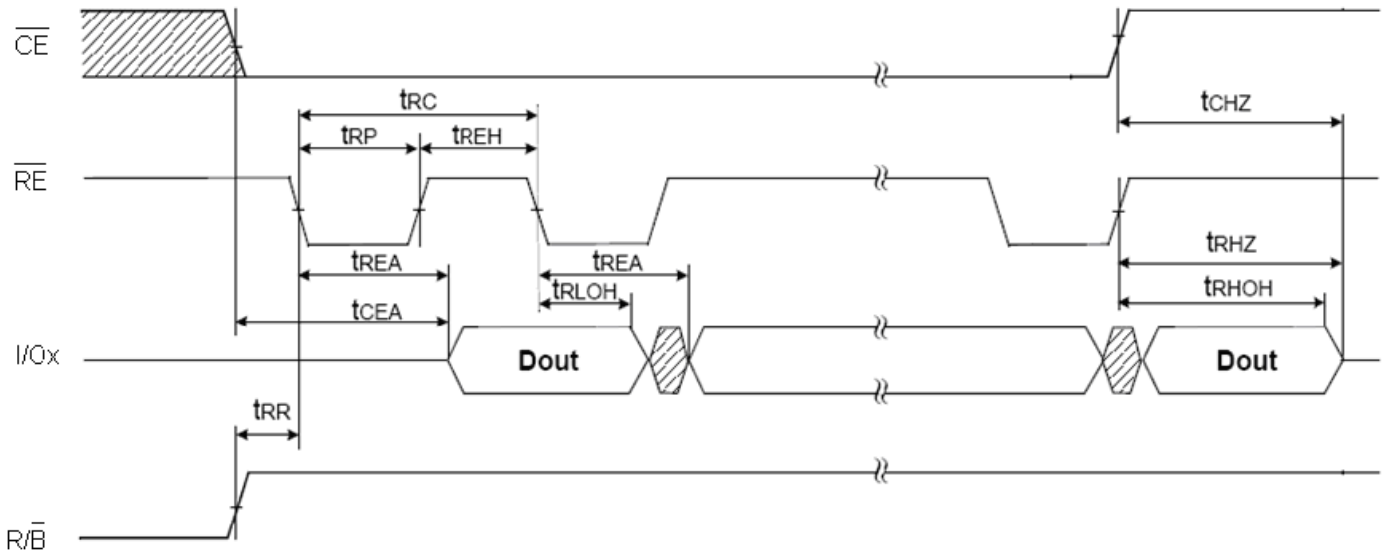

NOTE:

1. Transition is measured at $\pm 200\text{mV}$ from steady state voltage with load.
This parameter is sample and not 100% tested. (t_{CHZ} , t_{RHZ})
2. t_{RLOH} is valid when frequency is higher than 33MHz.
 t_{RHOH} starts to be valid when frequency is lower than 33MHz.

Status Read Cycle

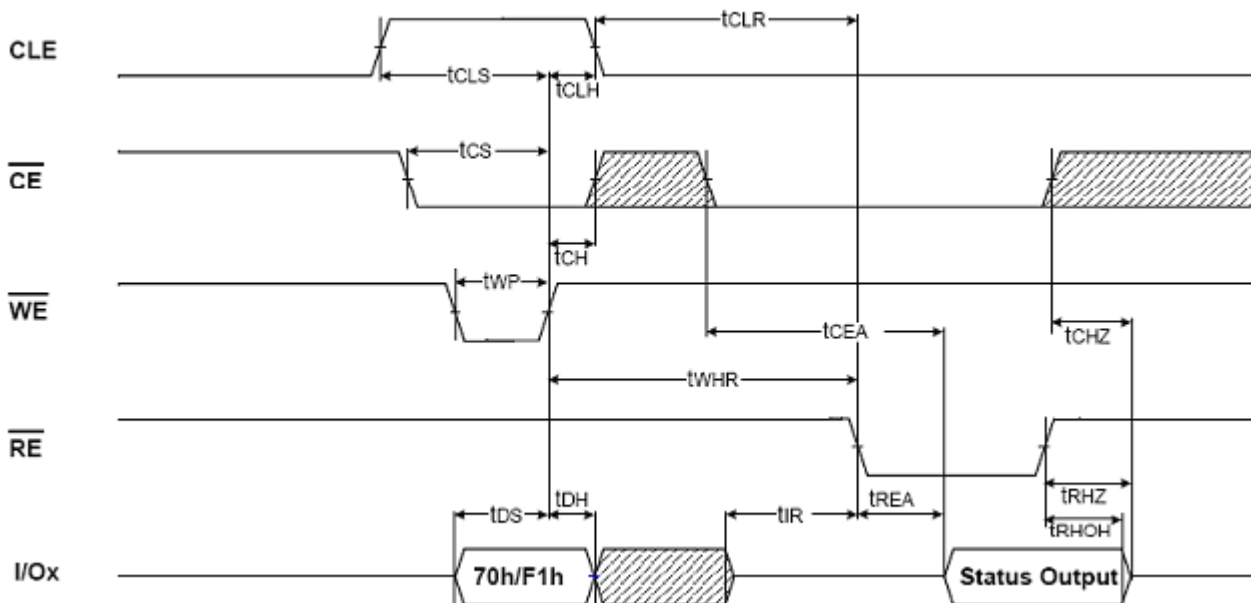

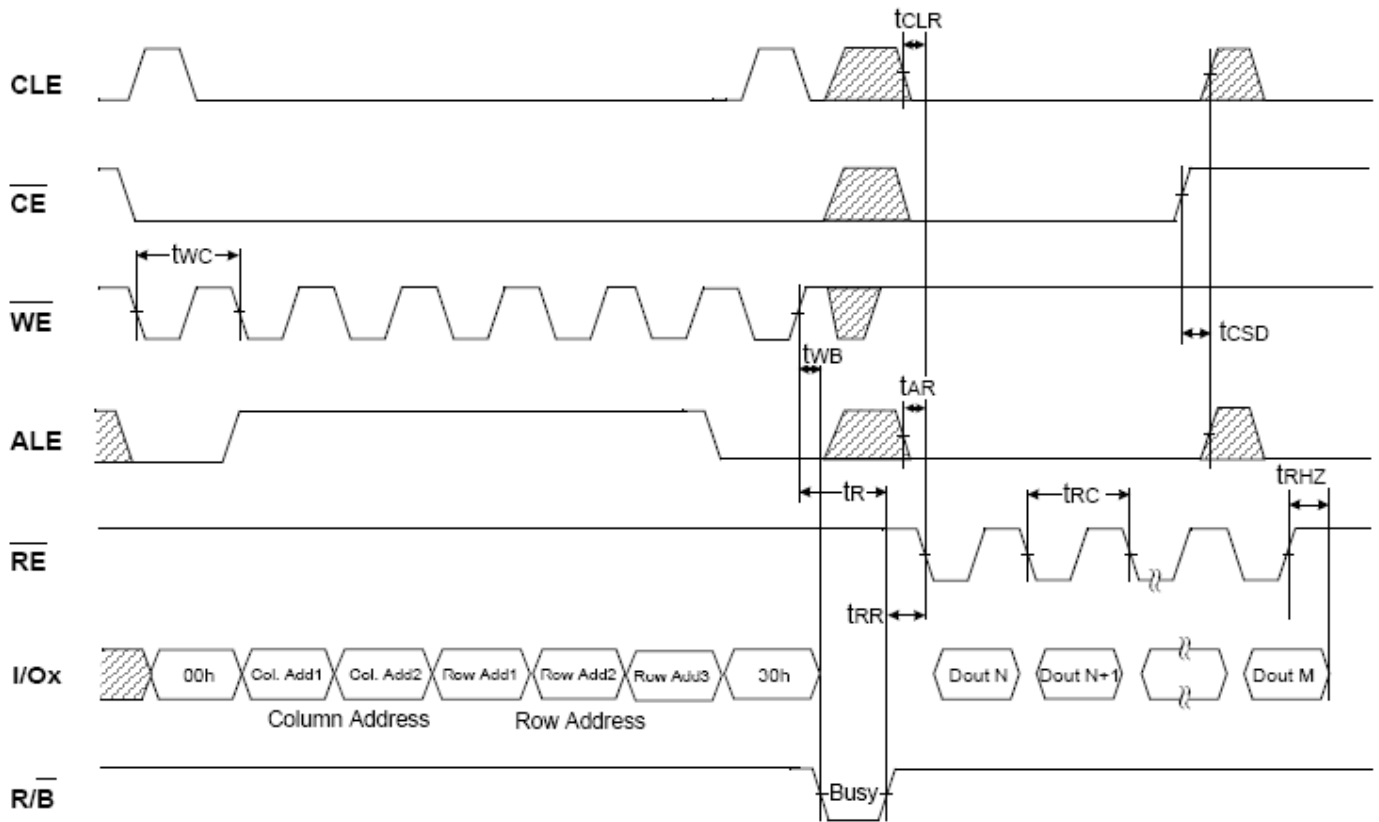
Read Operation (Read One Page)

Read Operation (Intercepted by \overline{CE})

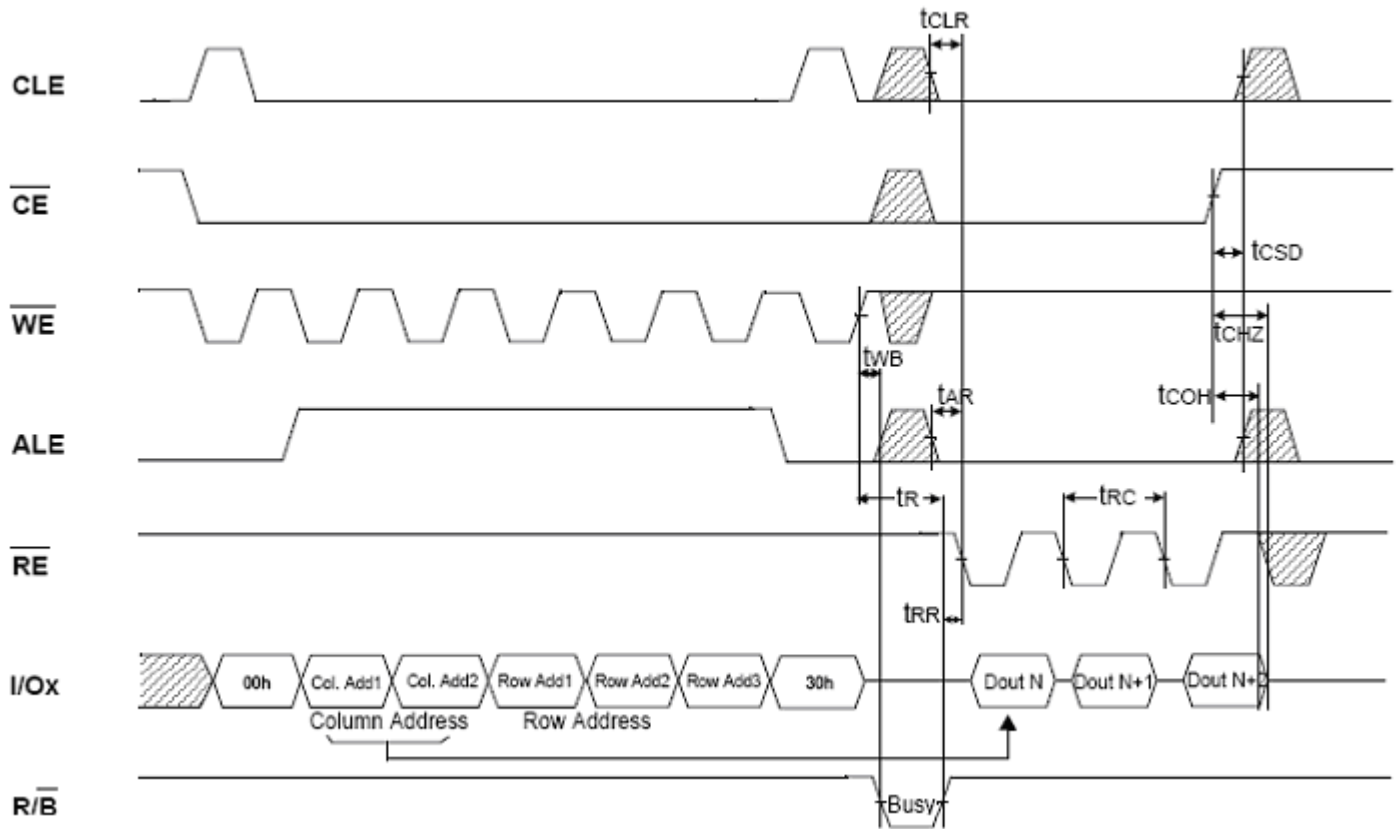

Random Data Output In a Page

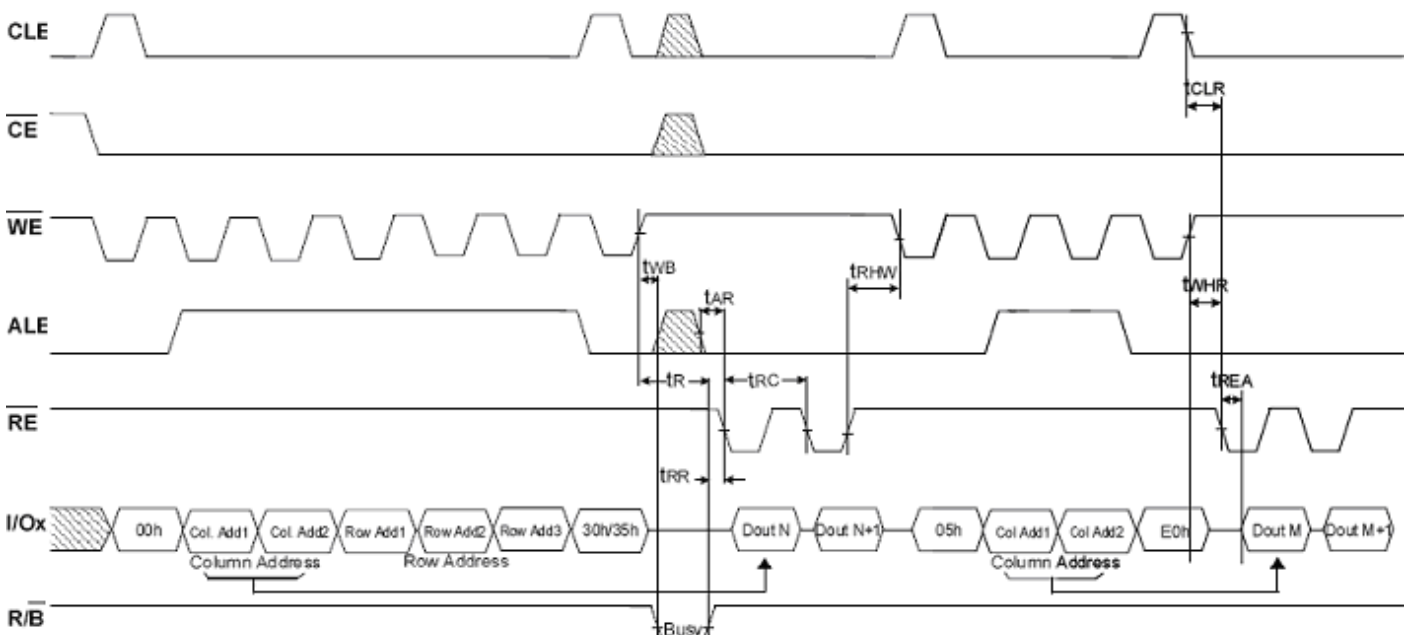

Page Program Operation

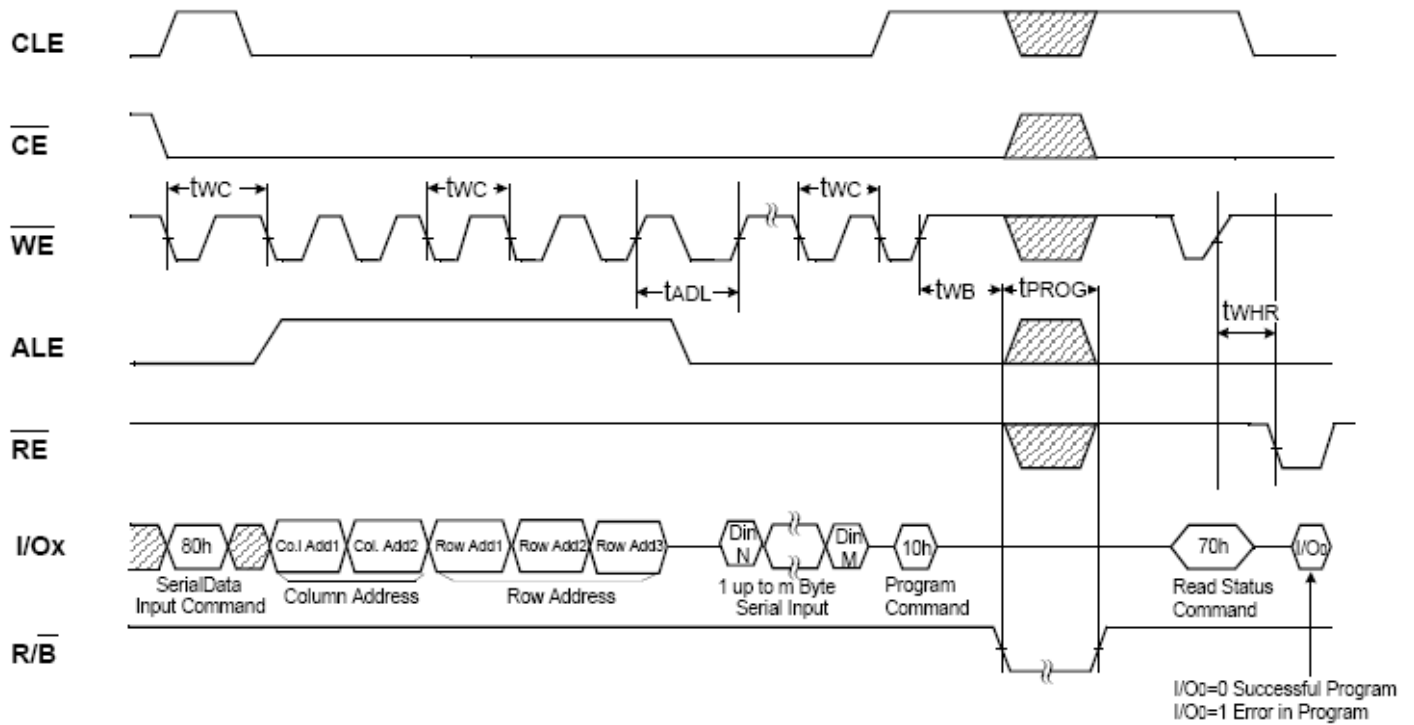

Page Program Operation with Random Data Input

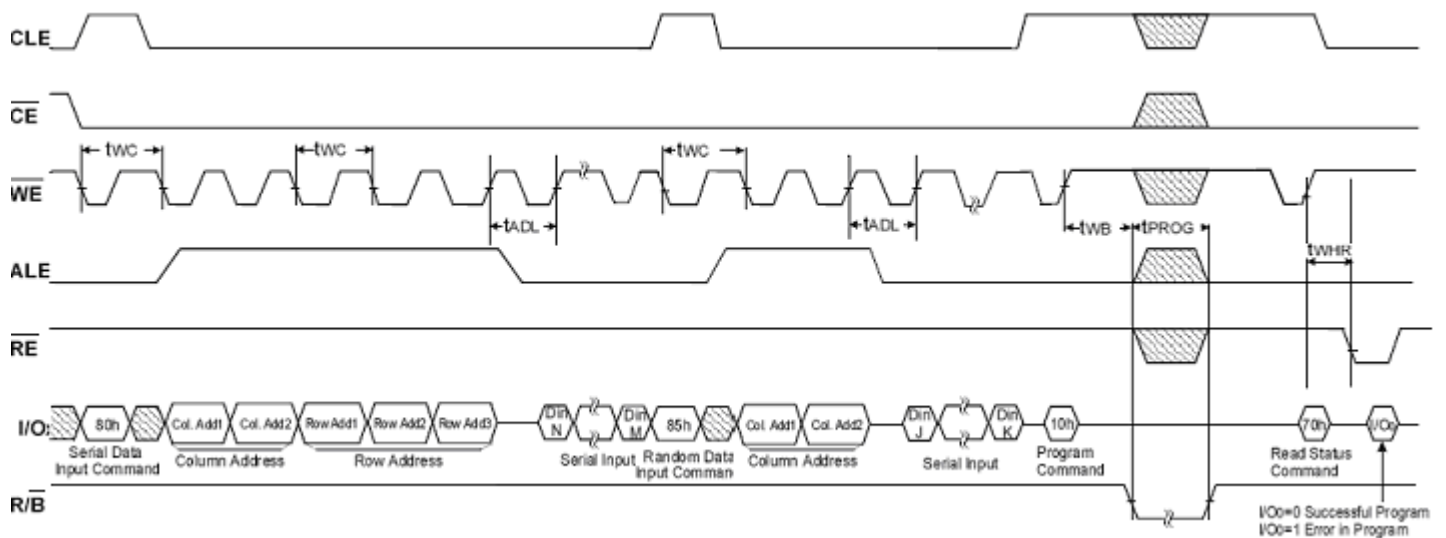

NOTE: t_{ADL} is the time from the \overline{WE} rising edge of final address cycle to the \overline{WE} rising edge of the first data cycle.

Copy-Back Operation with Random Data Input

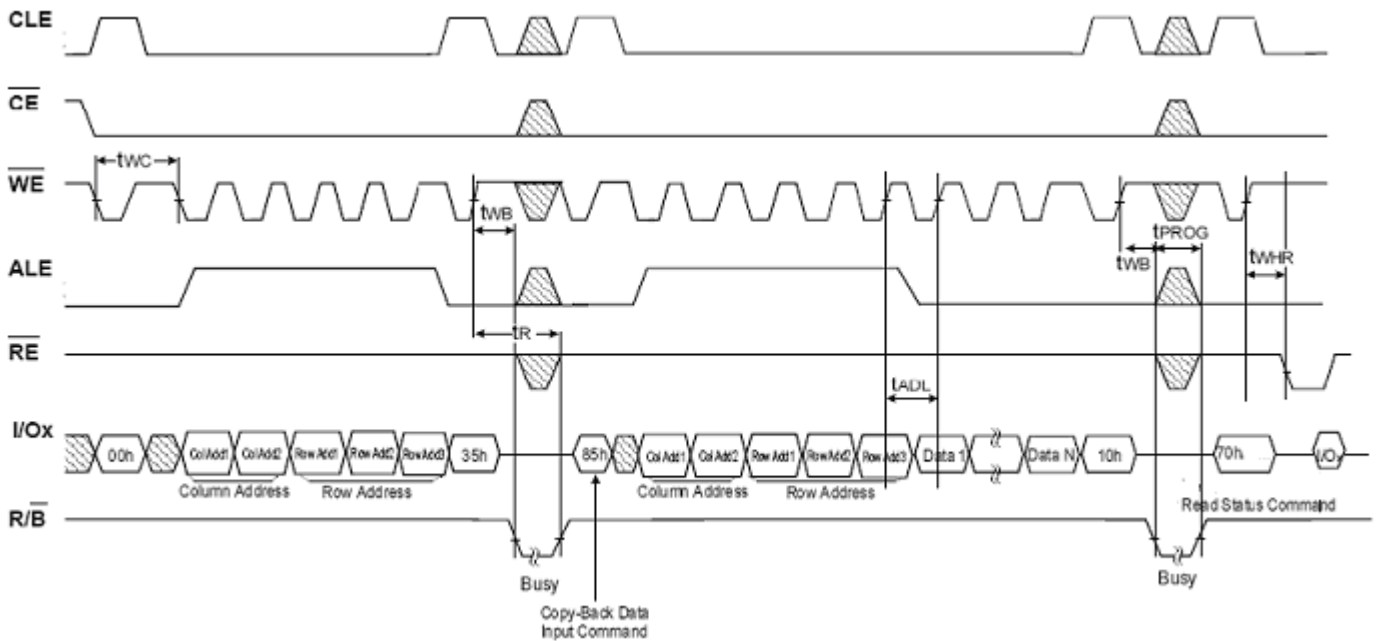

Cache Program Operation

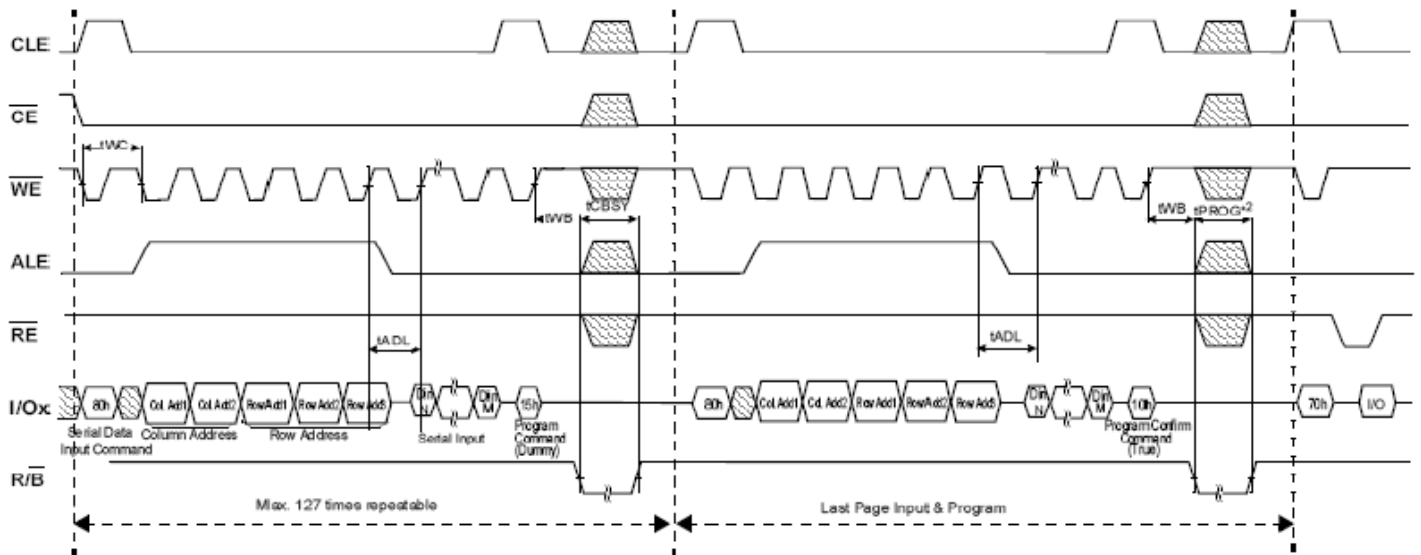

Block Erase Operation

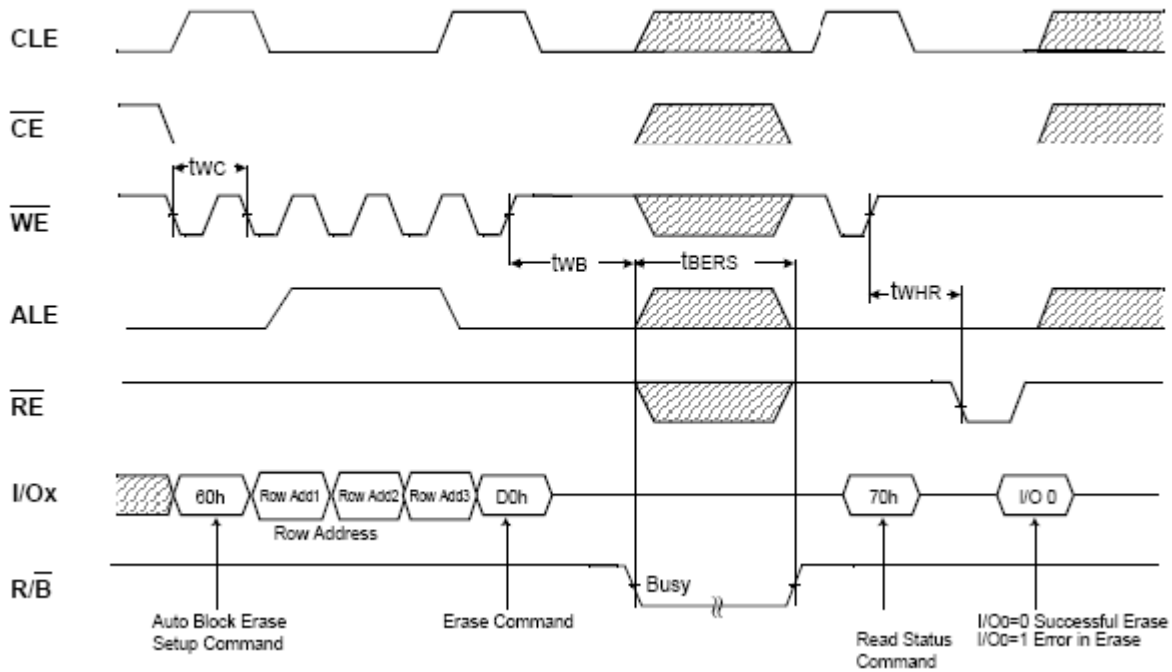

Read ID Operation

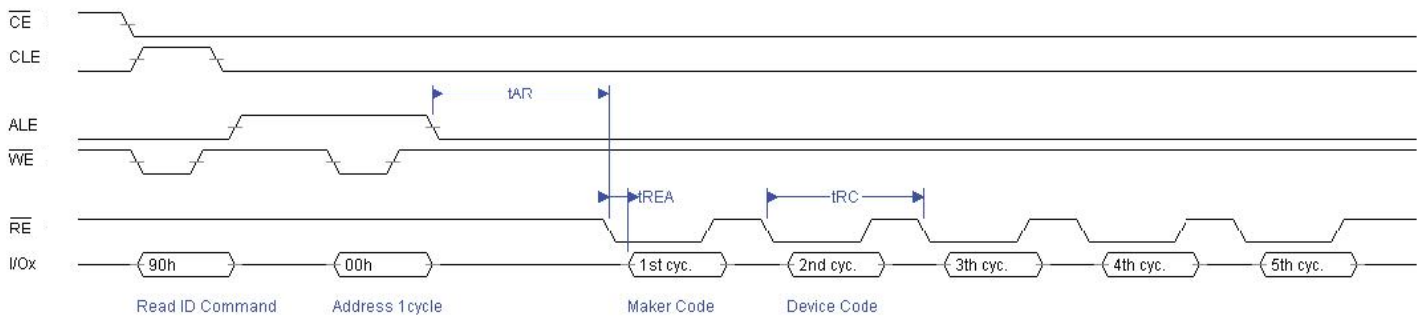

Two-plane Page Read Operation with Two-plane Random Data Out

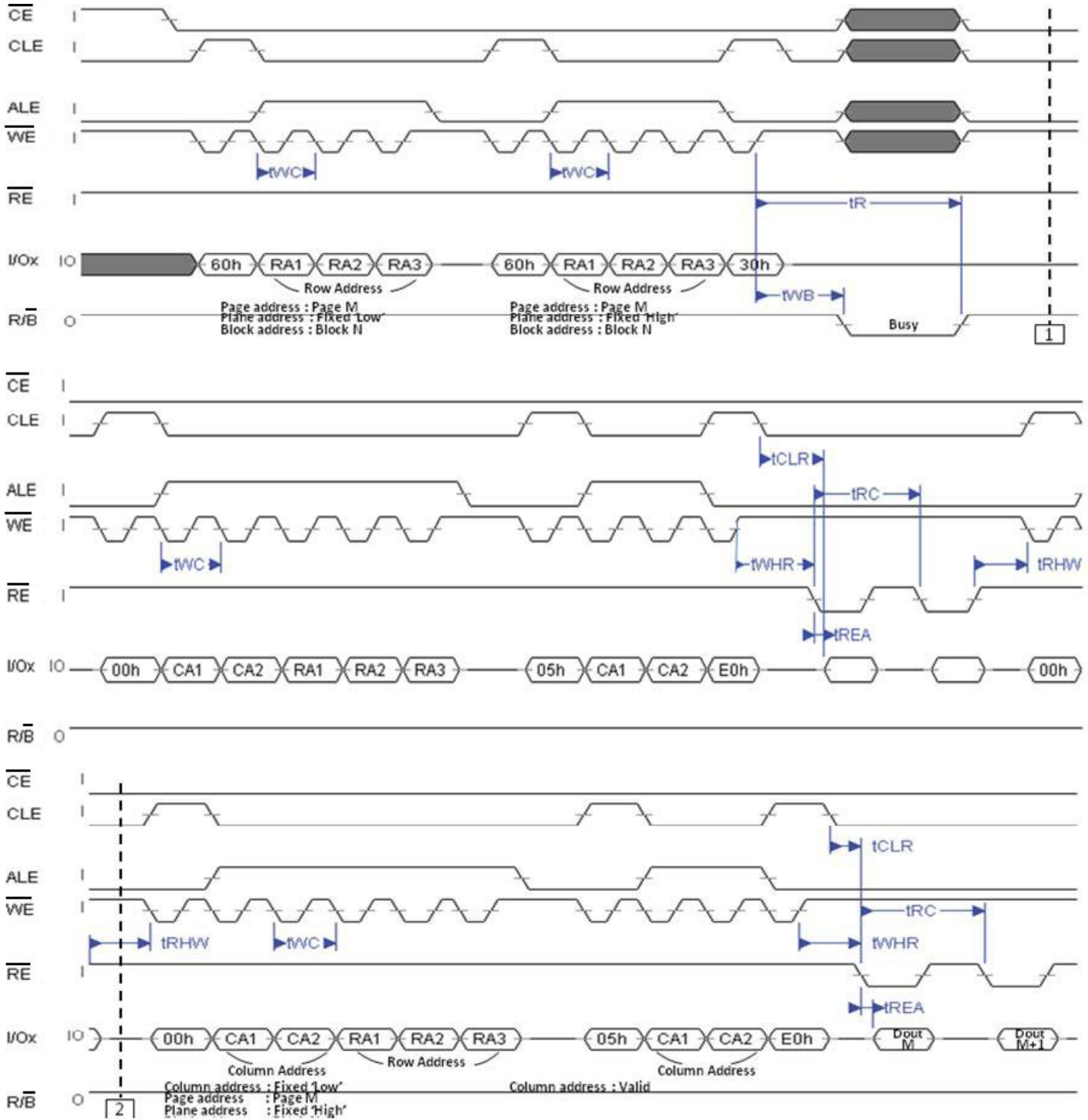

Two-plane Cache Read Operation

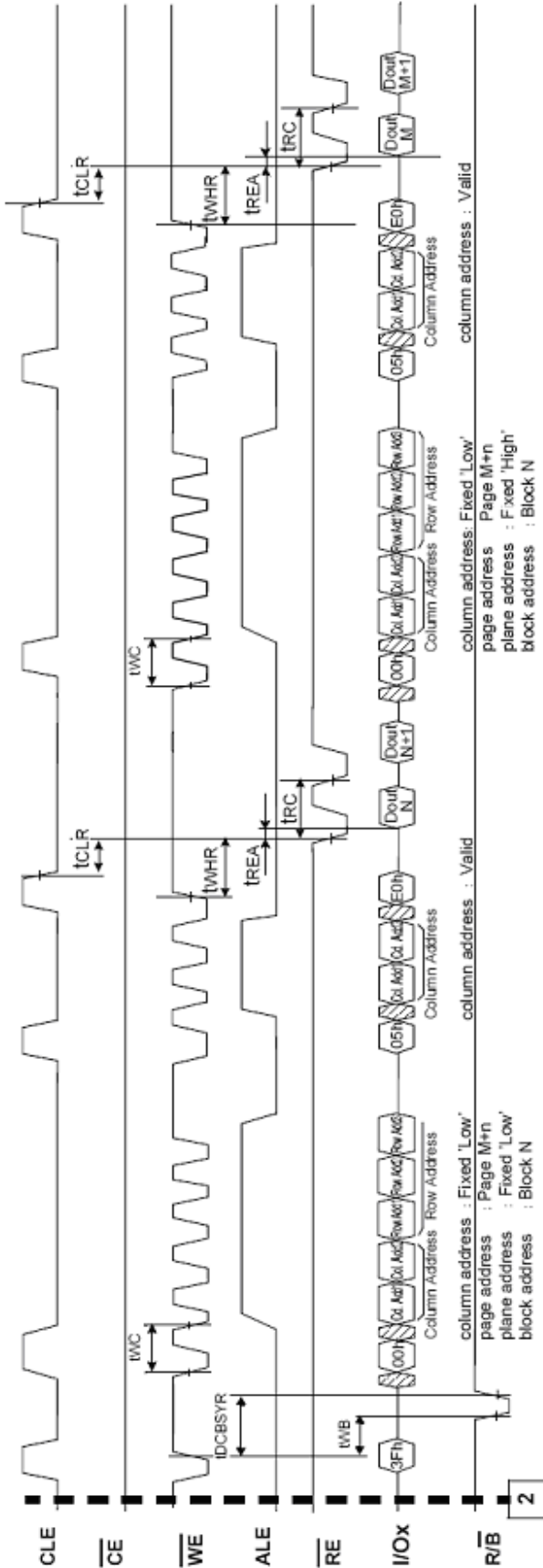

NOTE:

1. The column address will be reset to 0 by the 3Fh command input.
2. Cache Read operation is available only within a block.
3. Make sure to terminate the operation with 3Fh command. If the operation is terminated by 31h command, monitor I/O6 (Ready/Busy) by issuing Status Read Command (70h) and make sure the previous page read operation is completed. If the page read operation is completed, issue FFh reset before next operation.

Two-plane Page Program Operation

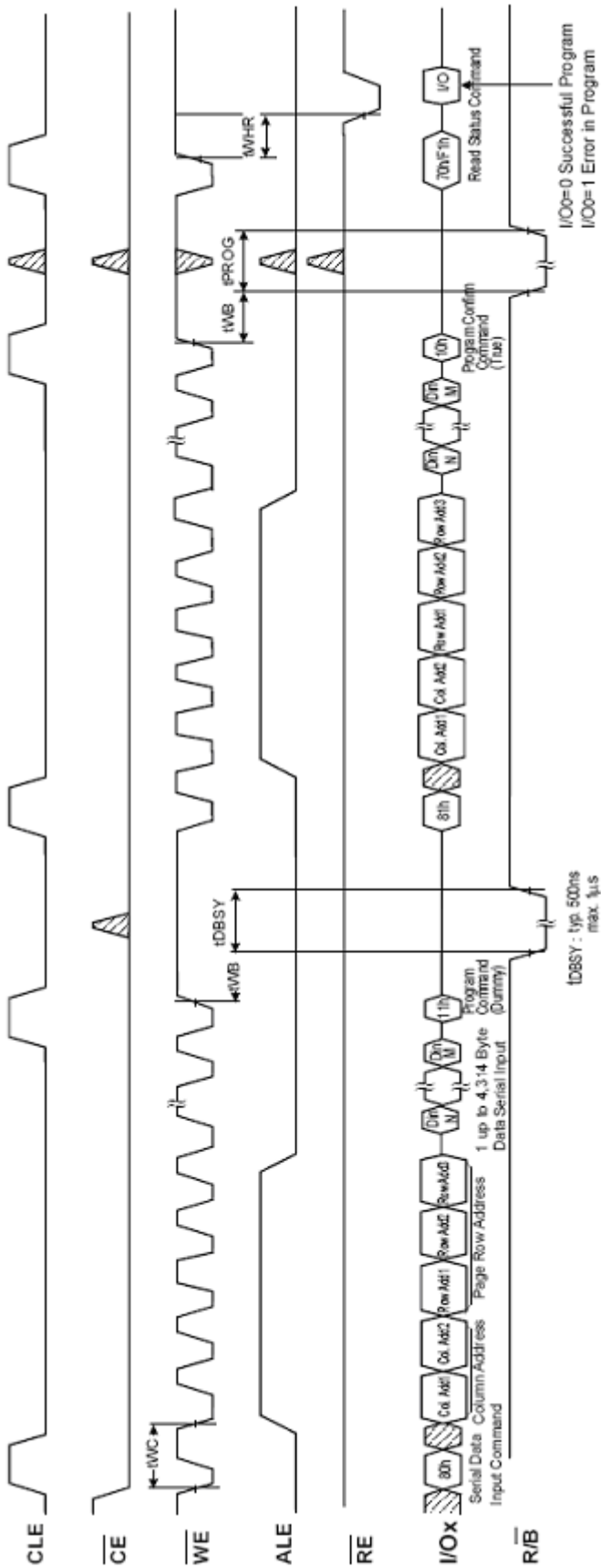

Two-plane Cache Program Operation

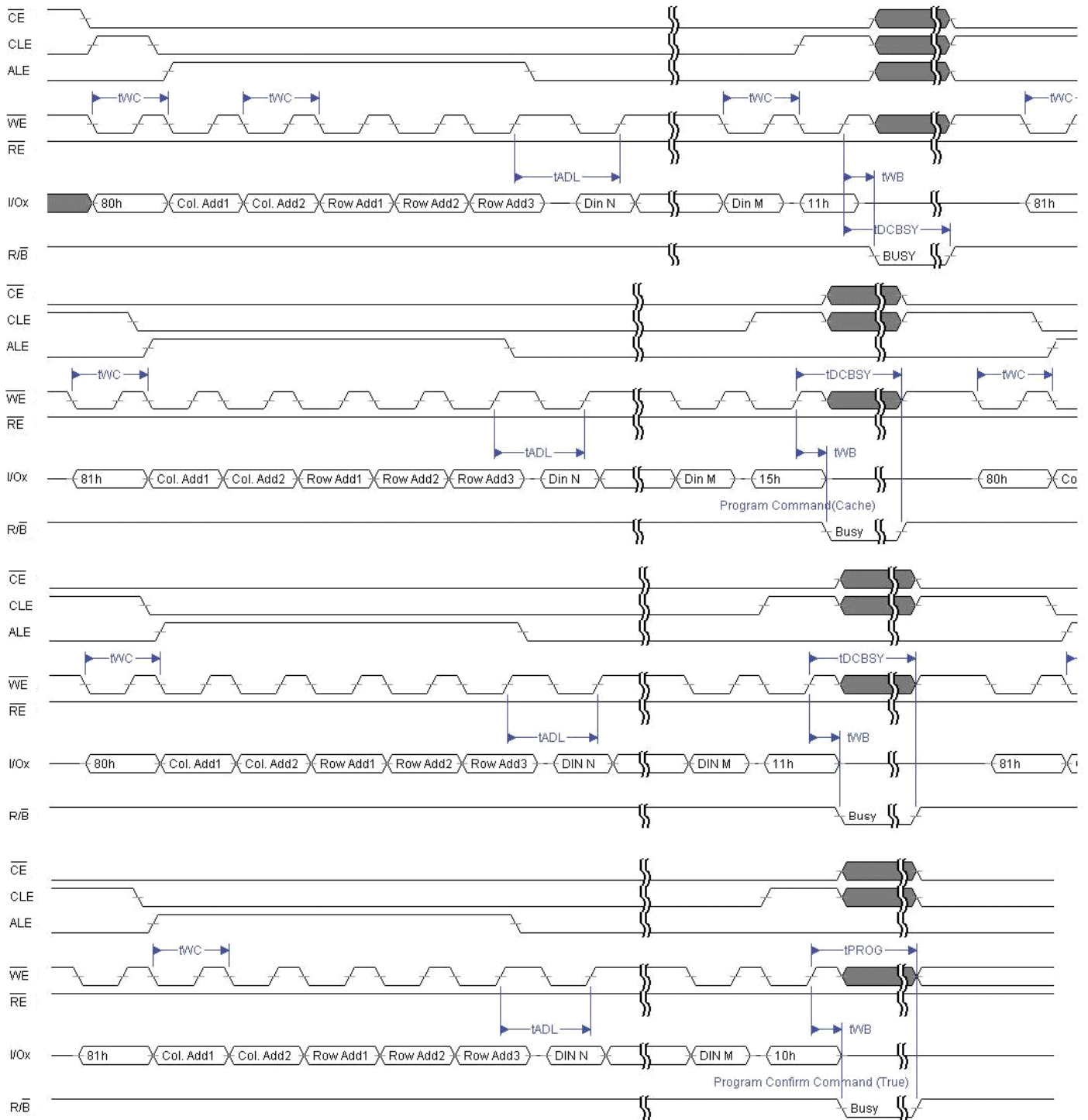

Two-plane Block Erase Operation

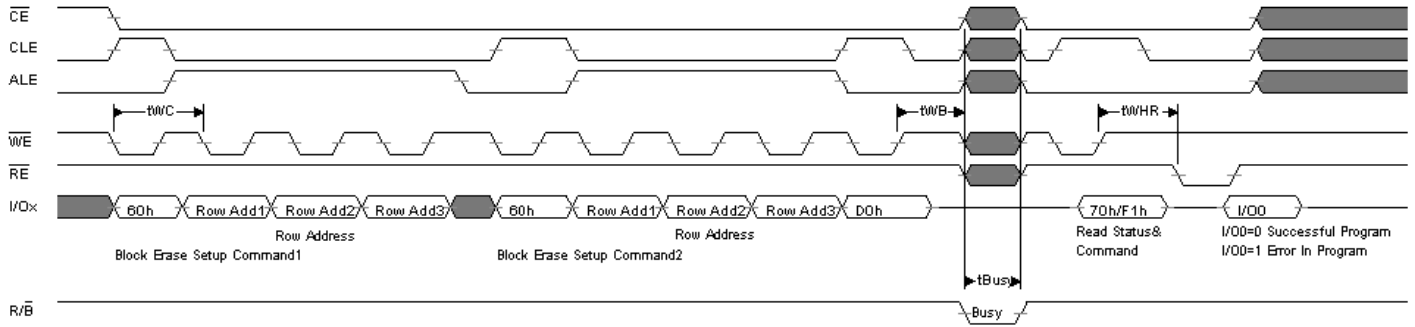

ID Definition Table

ID Access command = 90H

1 st Cycle (Maker Code)	2 nd Cycle (Device Code)	3 rd Cycle	4 th Cycle	5 th Cycle
C8h	DCh	90h	95h	54h

	Description
1 st Byte	Maker Code
2 nd Byte	Device Code
3 rd Byte	Internal Chip Number, Cell Type, etc
4 th Byte	Page Size, Block Size, etc
5 th Byte	Plane Number, Plane Size, ECC Level

3rd ID Data

	Description	I/O7	I/O6	I/O5	I/O4	I/O3	I/O2	I/O1	I/O0
Internal Chip Number	1							0	0
	2							0	1
	4							1	0
	8							1	1
Cell Type	2 Level Cell					0	0		
	4 Level Cell					0	1		
	8 Level Cell					1	0		
	16 Level Cell					1	1		
Number of Simultaneously Programmed Page	1			0	0				
	2			0	1				
	4			1	0				
	8			1	1				
Interleave Program Between multiple chips	Not Support		0						
	Support		1						
Cache Program	Not Support	0							
	Support	1							

4th ID Data

	Description	I/O7	I/O6	I/O5	I/O4	I/O3	I/O2	I/O1	I/O0
Page Size (w/o redundant area)	1KB							0	0
	2KB							0	1
	4KB							1	0
	8KB							1	1
Redundant Area Size (byte/512byte)	8						0		
	16						1		
Block Size (w/o redundant area)	64KB			0	0				
	128KB			0	1				
	256KB			1	0				
	512KB			1	1				
Organization	x8		0						
	x16		1						
Serial Access Time	45ns	0				0			
	Reserved	0				1			
	25ns	1				0			
	Reserved	1				1			

5th ID Data

	Description	I/O7	I/O6	I/O5	I/O4	I/O3	I/O2	I/O1	I/O0
Plane Number	1					0	0		
	2					0	1		
	4					1	0		
	8					1	1		
Plane Size (w/o redundant area)	64Mb		0	0	0				
	128Mb		0	0	1				
	256Mb		0	1	0				
	512Mb		0	1	1				
	1Gb		1	0	0				
	2Gb		1	0	1				
	4Gb		1	1	0				
8Gb		1	1	1					
Reserved	Reserved	0						0	0

DEVICE OPERATION

Page Read

Upon initial device power up, the device defaults to Read mode. This operation is also initiated by writing 00h command, five-cycle address, and 30h command. After initial power up, the 00h command can be skipped because it has been latched in the command register. The 2,112Byte of data on a page are transferred to cache registers via data registers within 25 μ s (t_R). Host controller can detect the completion of this data transfer by checking the R/ \bar{B} output. Once data in the selected page have been loaded into cache registers, each Byte can be read out in 25ns cycle time by continuously pulsing $\bar{R}\bar{E}$. The repetitive high-to-low transitions of $\bar{R}\bar{E}$ clock signal make the device output data starting from the designated column address to the last column address.

The device can output data at a random column address instead of sequential column address by using the Random Data Output command. Random Data Output command can be executed multiple times in a page.

After power up, device is in read mode so 00h command cycle is not necessary to start a read operation.

A page read sequence is illustrated in the following figure, where column address, page address are placed in between commands 00h and 30h. After t_R read time, the R/ \bar{B} de-asserts to ready state. Read Status command (70h) can be issued right after 30h. Host controller can toggle $\bar{R}\bar{E}$ to access data starting with the designated column address and their successive bytes.

Read Operation

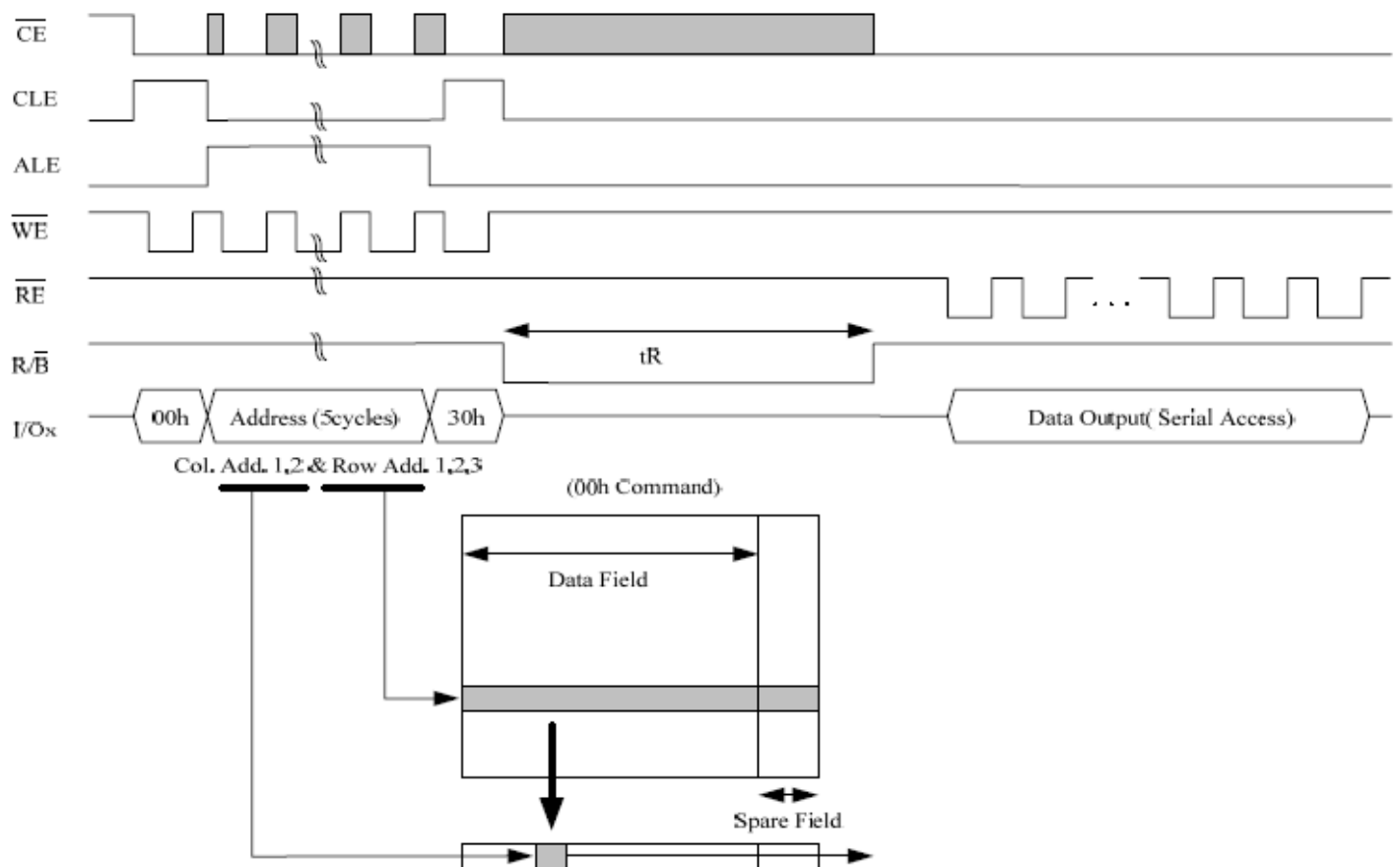

Random Data Output In a Page

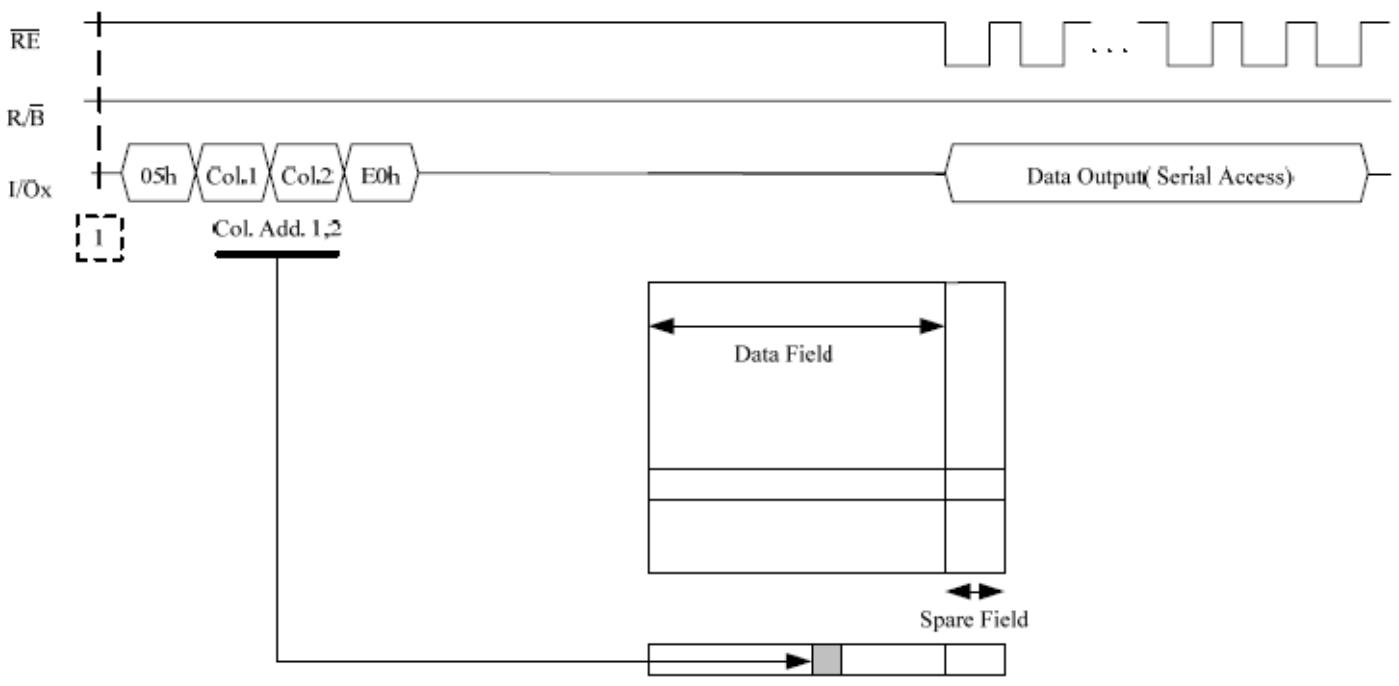
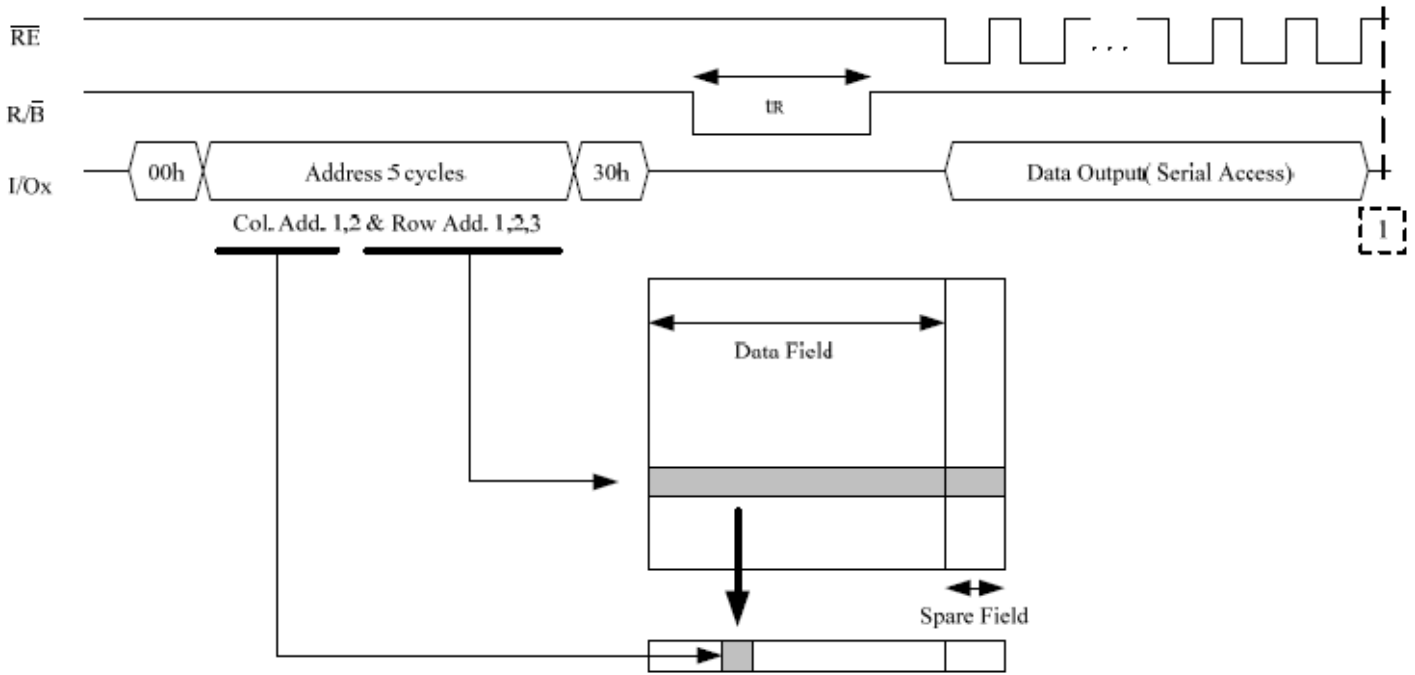

Page Program

The device is programmed based on the unit of a page, and consecutive partial page programming on one page without intervening erase operation is strictly prohibited. Addressing of page program operations within a block should be in sequential order. A complete page program cycle consists of a serial data input cycle in which up to 2,112byte (1,056word) of data can be loaded into data register via cache register, followed by a programming period during which the loaded data are programmed into the designated memory cells.

The serial data input cycle begins with the Serial Data Input command (80h), followed by a five-cycle address input and then serial data loading. The bytes not to be programmed on the page do not need to be loaded. The column address for the next data can be changed to the address follows Random Data Input command (85h). Random Data Input command may be repeated multiple times in a page. The Page Program Confirm command (10h) starts the programming process. Writing 10h alone without entering data will not initiate the programming process. The internal write engine automatically executes the corresponding algorithm and controls timing for programming and verification, thereby freeing the host controller for other tasks. Once the program process starts, the host controller can detect the completion of a program cycle by monitoring the R/\bar{B} output or reading the Status bit (I/O6) using the Read Status command. Only Read Status and Reset commands are valid during programming. When the Page Program operation is completed, the host controller can check the Status bit (I/O0) to see if the Page Program operation is successfully done. The command register remains the Read Status mode unless another valid command is written to it.

A page program sequence is illustrated in following figure, where column address, page address, and data input are placed in between 80h and 10h. After t_{PROG} program time, the R/\bar{B} de-asserts to ready state. Read Status command (70h) can be issued right after 10h.

Program & Read Status Operation

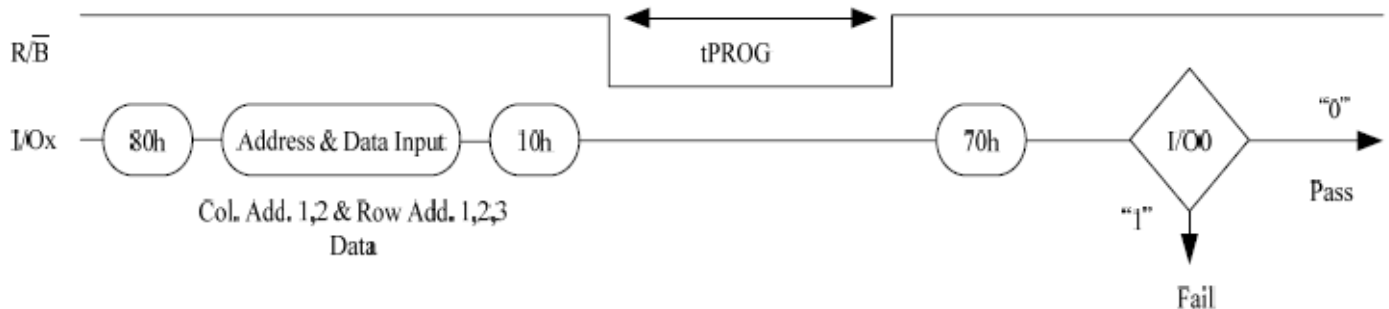

Random Data Input In a page

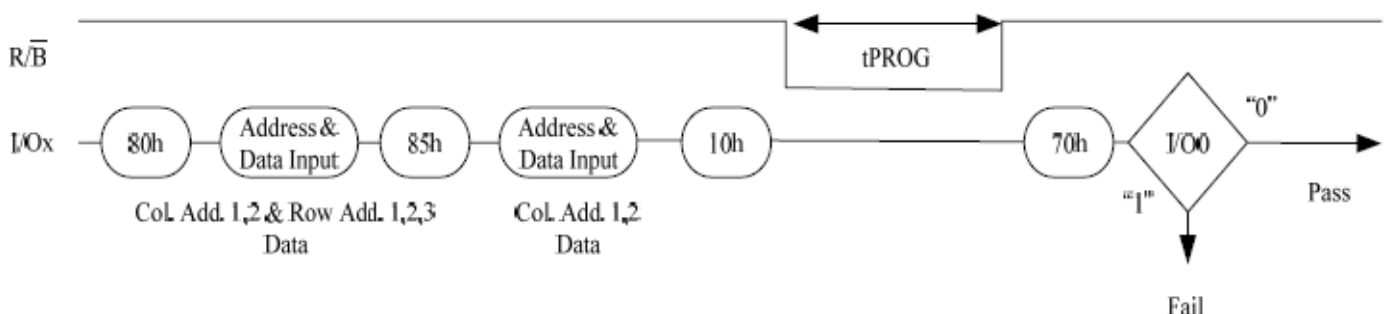

Cache Program

Cache Program is an extension of Page Program, which is executed with 2,112 byte (x8) data registers, and is available only within a block. Since the device has 1 page of cache memory, serial data input may be executed while data stored in data register are programmed into memory cell.

After writing the first set of data up to 2,112 bytes (x8) into the selected cache registers, Cache Program command (15h) instead of actual Page Program (10h) is inputted to make cache registers free and to start internal program operation. To transfer data from cache registers to data registers, the device remains in Busy state for a short period of time (t_{CBSY}) and has its cache registers ready for the next data-input while the internal programming gets started with the data loaded into data registers. Read Status command (70h) may be issued to find out when cache registers become ready by polling the Cache-Busy status bit (I/O6). Pass/fail status of only the previous page is available upon the return to Ready state. When the next set of data is inputted with the Cache Program command, t_{CBSY} is affected by the progress of pending internal programming. The programming of the cache registers is initiated only when the pending program cycle is finished and the data registers are available for the transfer of data from cache registers. The status bit (I/O5) for internal Ready/Busy may be polled to identify the completion of internal programming. If the system monitors the progress of programming only with R/\bar{B} , the last page of the target programming sequence must be programmed with actual Page Program command (10h).

Cache Program (available only within a block)

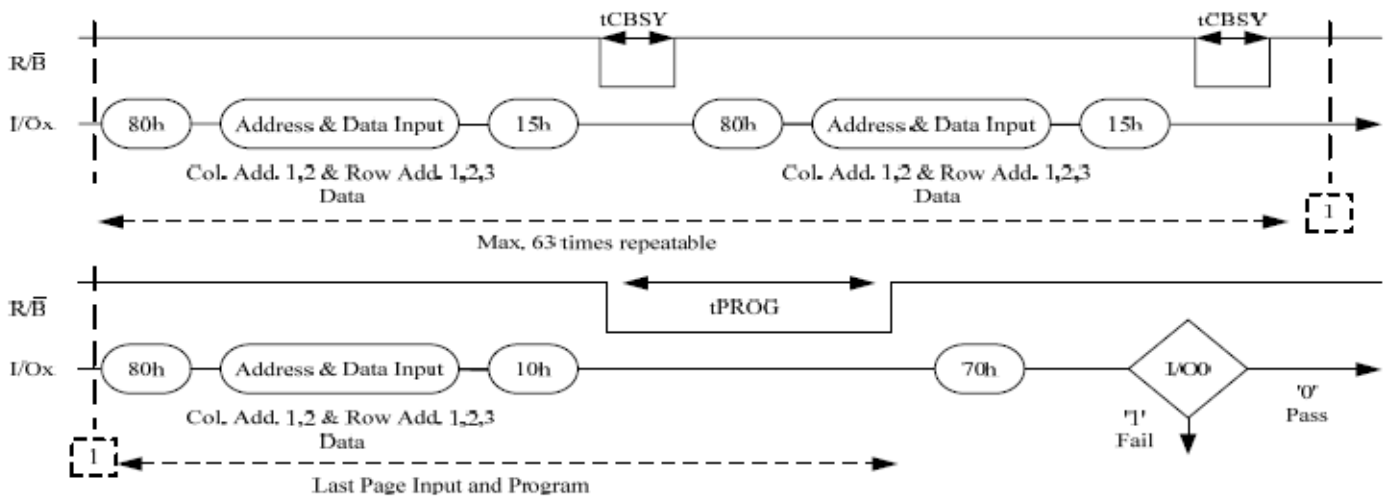

NOTE:

1. Since programming the last page does not employ caching, the program time has to be that of Page Program. However, if the previous program cycle with the cache data has not finished, the actual program cycle of the last page is initiated only after completion of the previous cycle, which can be expressed as the following formula.
2. $t_{PROG} = \text{Program time for the last page} + \text{Program time for the (last-1)th page} - (\text{Program command cycle time} + \text{Last page data loading time})$

Copy-Back Program

Copy-Back Program is designed to efficiently copy data stored in memory cells without time-consuming data reloading when there is no bit error detected in the stored data. The benefit is particularly obvious when a portion of a block is updated and the rest of the block needs to be copied to a newly assigned empty block. Copy-Back operation is a sequential execution of Read for Copy-Back and of Copy-Back Program with Destination address. A Read for Copy-Back operation with “35h” command and the Source address moves the whole 2,112 byte data into the internal buffer. The host controller can detect bit errors by sequentially reading the data output. Copy-Back Program is initiated by issuing Page-Copy Data-Input command (85h) with Destination address. If data modification is necessary to correct bit errors and to avoid error propagation, data can be reloaded after the Destination address. Data modification can be repeated multiple times as shown in the following figure. Actual programming operation begins when Program Confirm command (10h) is issued. Once the program process starts, the Read Status command (70h) may be entered to read the status register. The host controller can detect the completion of a program cycle by monitoring the R/\bar{B} output, or the Status bit (I/O6) of the Status Register. When the Copy-Back Program is complete, the Status Bit (I/O0) may be checked. The command register remains Read Status mode until another valid command is written to it.

Page Copy-Back Program Operation

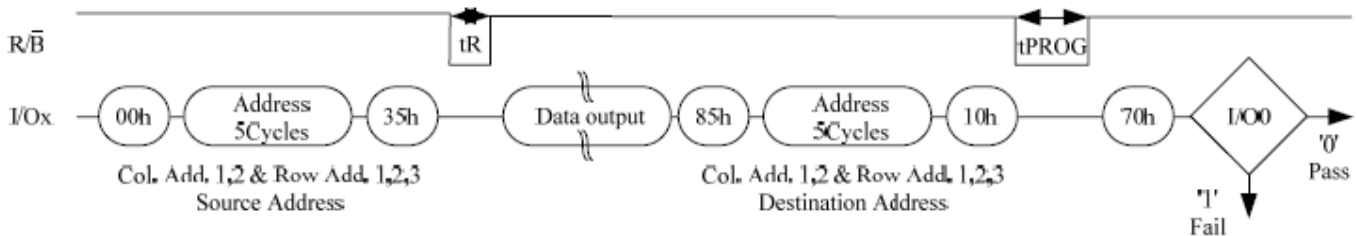

Page Copy-Back Program Operation with Random Data Input

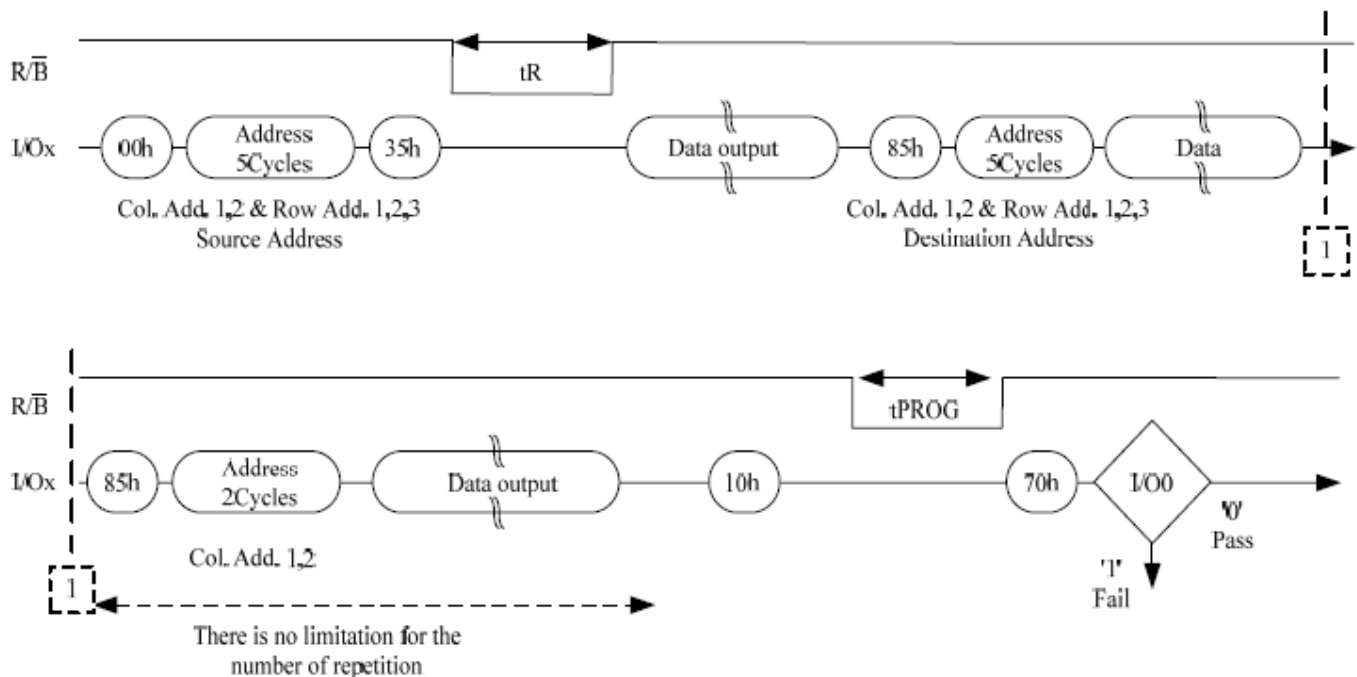

Block Erase

The block-based Erase operation is initiated by an Erase Setup command (60h), followed by a three-cycle row address, in which only Plane address and Block address are valid while Page address is ignored. The Erase Confirm command (D0h) following the row address starts the internal erasing process. The two-step command sequence is designed to prevent memory content from being inadvertently changed by external noise.

At the rising edge of \overline{WE} after the Erase Confirm command input, the internal control logic handles erase and erase-verify. When the erase operation is completed, the host controller can check Status bit (I/O0) to see if the erase operation is successfully done. The following figure illustrates a block erase sequence, and the address input (the first page address of the selected block) is placed in between commands 60h and D0h. After t_{BERS} erase time, the R/\overline{B} de-asserts to ready state. Read Status command (70h) can be issued right after D0h to check the execution status of erase operation.

Block Erase Operation

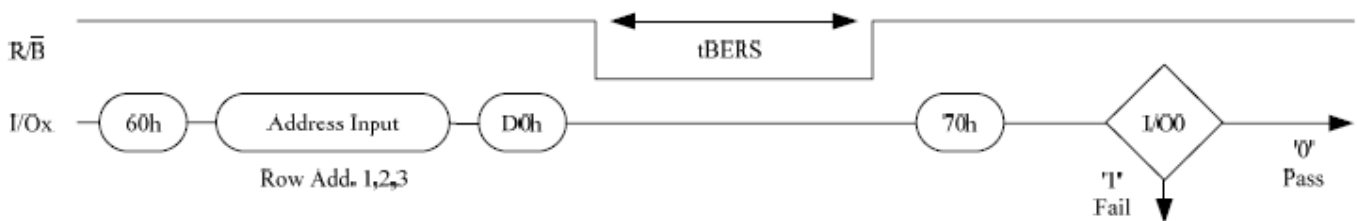

Read Status

A status register on the device is used to check whether program or erase operation is completed and whether the operation is completed successfully. After writing 70h/F1h command to the command register, a read cycle outputs the content of the status register to I/O pins on the falling edge of \overline{CE} or \overline{RE} , whichever occurs last. These two commands allow the system to poll the progress of each device in multiple memory connections even when R/\overline{B} pins are common-wired. \overline{RE} or \overline{CE} does not need to toggle for status change.

The command register remains in Read Status mode unless other commands are issued to it. Therefore, if the status register is read during a random read cycle, a read command (00h) is needed to start read cycles.

Status Register Definition for 70h Command

I/O	Page Program	Block Erase	Cache Program	Read	Cache Read	Definition
I/O0	Pass / Fail	Pass / Fail	Pass / Fail (N)	NA	NA	Pass: "0" Fail: "1"
I/O1	NA (Pass/Fail, OTP)	NA	Pass / Fail (N-1)	NA	NA	Don't cared
I/O2	NA	NA	NA	NA	NA	Don't cared
I/O3	NA	NA	NA	NA	NA	Don't cared
I/O4	NA	NA	NA	NA	NA	Don't cared
I/O5	NA	NA	True Ready / Busy	NA	True Ready / Busy	Busy: "0" Ready: "1"
I/O6	Ready / Busy	Ready / Busy	Ready / Busy	Ready / Busy	Ready / Busy	Busy: "0" Ready: "1"
I/O7	Write Protect	Write Protect	Write Protect	Write Protect	Write Protect	Protected: "0" Not Protected: "1"

Status Register Definition for F1h Command

I/O	Page Program	Block Erase	Cache Program	Read	Cache Read	Definition
I/O0	Chip Pass / Fail	Chip Pass / Fail	Chip Pass / Fail (N)	NA	NA	Pass: "0" Fail: "1"
I/O1	Plane0 Pass / Fail	Plane0 Pass / Fail	Plane0 Pass / Fail (N)	NA	NA	Pass: "0" Fail: "1"
I/O2	Plane1 Pass / Fail	Plane1 Pass / Fail	Plane1 Pass / Fail (N)	NA	NA	Pass: "0" Fail: "1"
I/O3	NA	NA	Plane0 Pass / Fail (N-1)	NA	NA	Pass: "0" Fail: "1"
I/O4	NA	NA	Plane1 Pass / Fail (N-1)	NA	NA	Pass: "0" Fail: "1"
I/O5	NA	NA	True Ready / Busy	NA	True Ready / Busy	Busy: "0" Ready: "1"
I/O6	Ready / Busy	Ready / Busy	Ready / Busy	Ready / Busy	Ready / Busy	Busy: "0" Ready: "1"
I/O7	Write Protect	Write Protect	Write Protect	Write Protect	Write Protect	Protected: "0" Not Protected: "1"

NOTE:

1. I/Os defined NA are recommended to be masked out when Read Status is being executed.
2. n : current page, n-1 : previous page.

Read ID

The device contains a product identification mode, initiated by writing 90h to the command register, followed by an address input of 00h. Four read cycles sequentially output the manufacturer code (C8h), and the device code and 3rd, 4th, 5th cycle ID respectively. The command register remains in Read ID mode until further commands are issued to it.

Read ID Operation

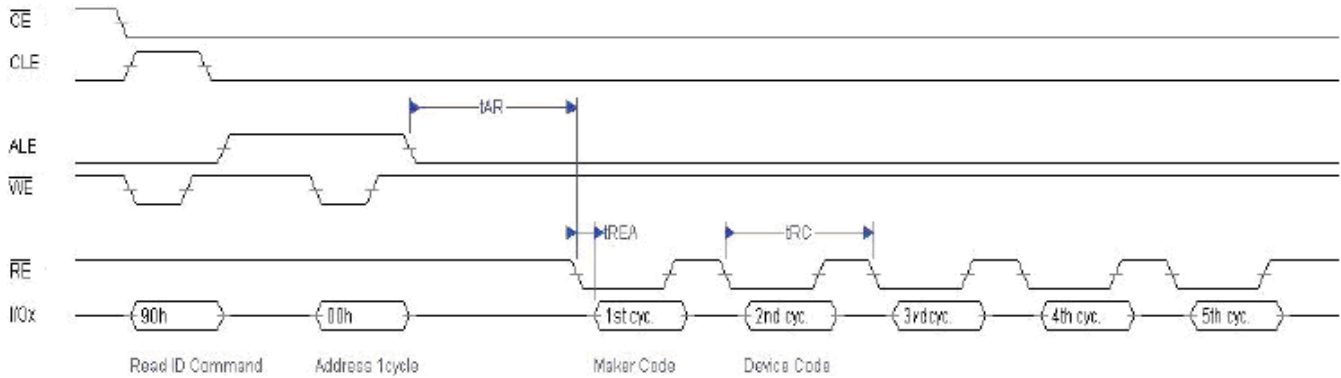

ID Definition Table

1 st Cycle (Maker Code)	2 nd Cycle (Device Code)	3 rd Cycle	4 th Cycle	5 th Cycle
C8h	DCh	90h	95h	54h

Reset

The device offers a reset feature, executed by writing FFh to the command register. When the device is in Busy state during random read, program or erase mode, the reset operation will abort these operations. The contents of memory cells being altered are no longer valid, as the data will be partially programmed or erased. The command register is cleared to wait for the next command, and the Status Register is cleared to value C0h when \overline{WP} is high. If the device is already in reset state a new reset command will be accepted by the command register. The $\overline{R/\overline{B}}$ pin changes to low for t_{RST} after the Reset command is written. Refer to the following figure.

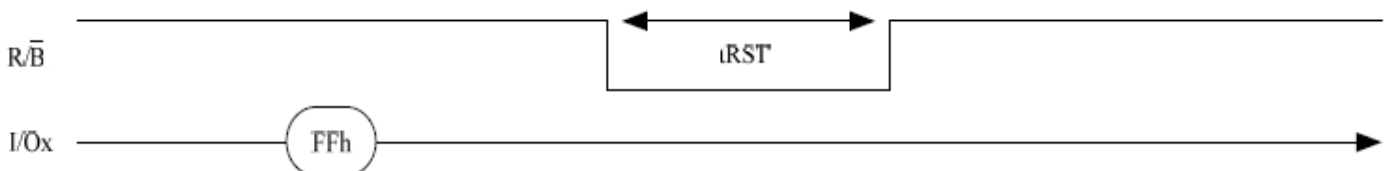

Device Status

	After Power-up	After Reset
Operation mode	00h Command is latched	Waiting for next command

Cache Read

Cache Read is an extension of Page Read, and is available only within a block. The normal Page Read command (00h-30h) is always issued before invoking Cache Read. After issuing the Cache Read command (31h), read data of the designated page (page N) are transferred from data registers to cache registers in a short time period of t_{DCBSYR} , and then data of the next page (page N+1) is transferred to data registers while the data in the cache registers are being read out. Host controller can retrieve continuous data and achieve fast read performance by iterating Cache Read operation. The Read Start for Last Page Cache Read command (3Fh) is used to complete data transfer from memory cells to data registers.

Read Operation with Cache Read

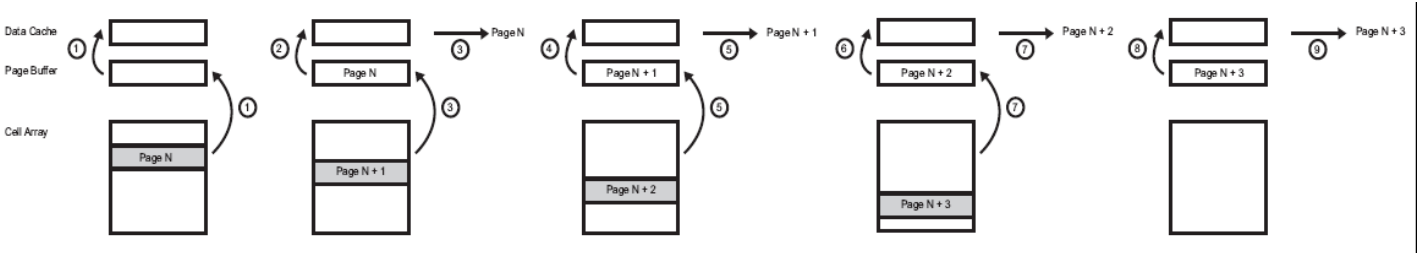
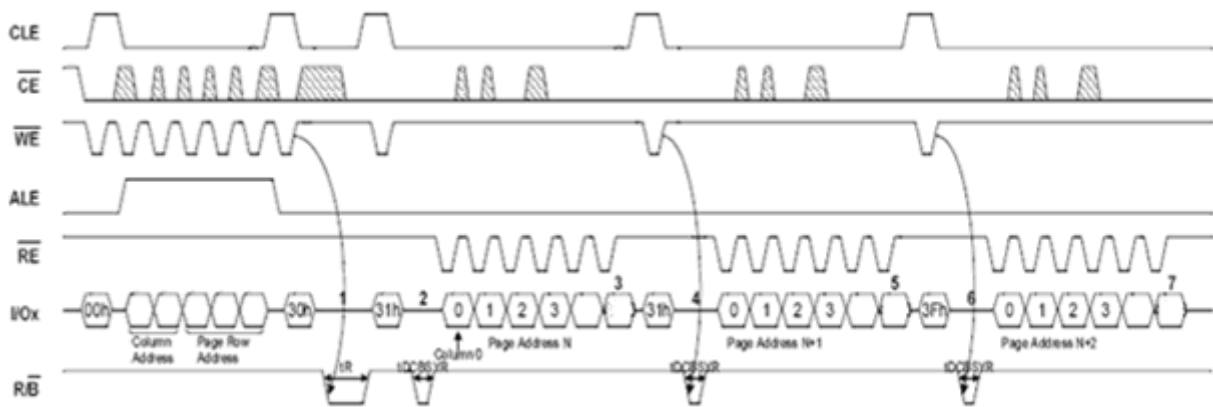

Two-Plane Page Read

Two-Plane Page Read is an extension of Page Read, for a single plane with 2,112 byte data registers. Since the device is equipped with two memory planes, activating the two sets of 2,112 byte data registers enables a random read of two pages. Two-Plane Page Read is initiated by repeating command 60h followed by three address cycles twice. In this case, only same page of same block can be selected from each plane.

After Read Confirm command (30h) the 4,224 bytes of data within the selected two page are transferred to the cache registers via data registers in less than 25us (t_R). The system controller can detect the completion of data transfer (t_R) by monitoring the output of R/B pin.

Once the data is loaded into the cache registers, the data output of first plane can be read out by issuing command 00h with five address cycles, command 05h with two column address and finally E0h. The data output of second plane can be read out using the identical command sequences.

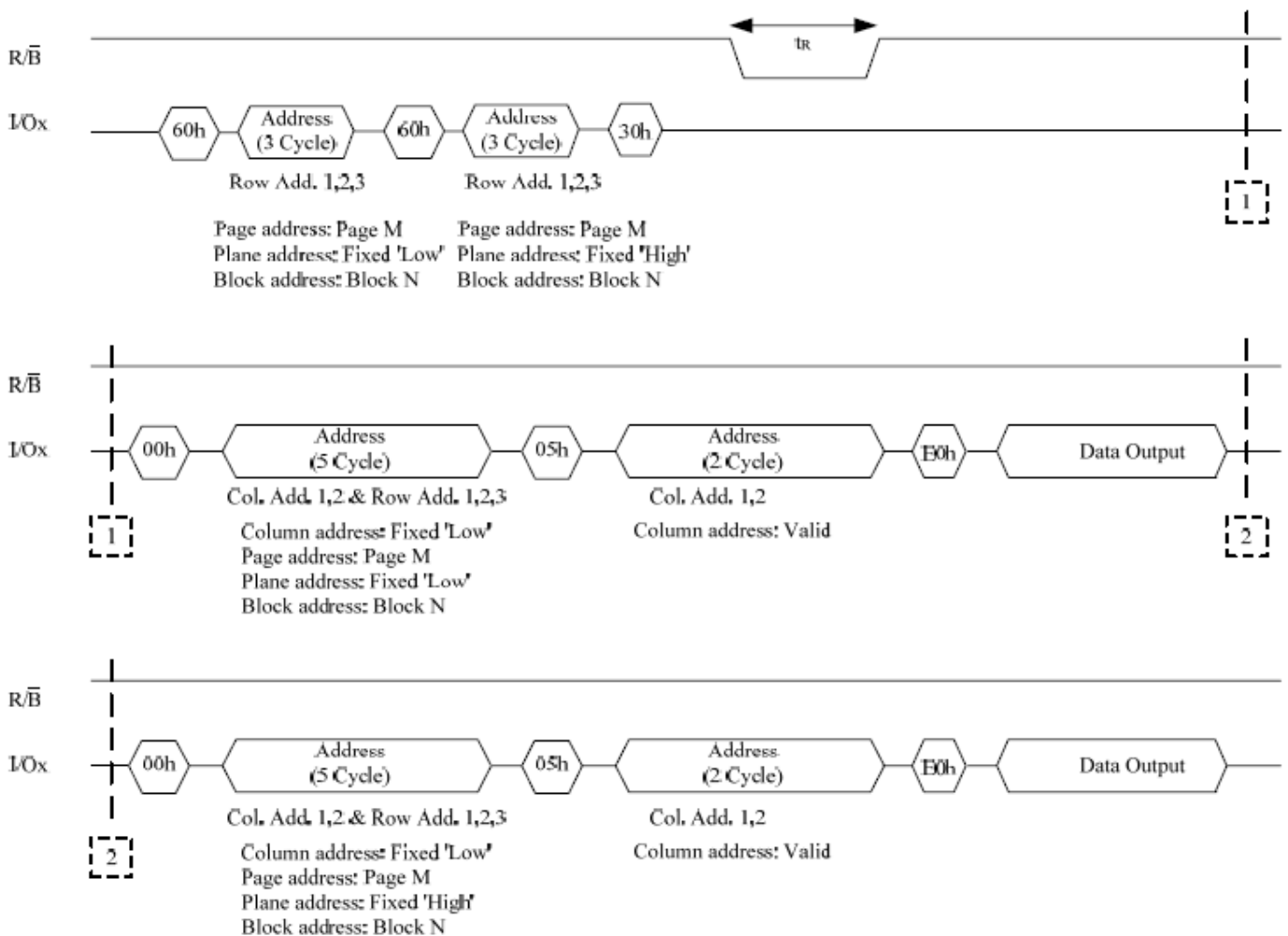

Two-Plane Cache Read

Two-Plane Cache Read is an extension of Cache Read, for a single plane with 2,112 byte data registers. Since the device is equipped with two memory planes, the two sets of 2,112 byte data registers enables a cache read of two pages. Two-Plane Cache Read is initiated by repeating command 60h followed by three address cycles twice. In this case only same page of same block can be selected from each plane.

After Read Confirm command(33h) the 4,224 bytes of data within the selected two page are transferred to the cache registers via data registers in less than 25us (t_R). After issuing Cache Read command (31h), read data in the data registers is transferred to cache registers for a short period of time (t_{DBSV}). Once the data is loaded into the cache registers from data registers, the data output of first plane can be read out by issuing command 00h with five address cycles, command 05h with two column address and finally E0h. The data output of second plane can be read out using the identical command sequences.

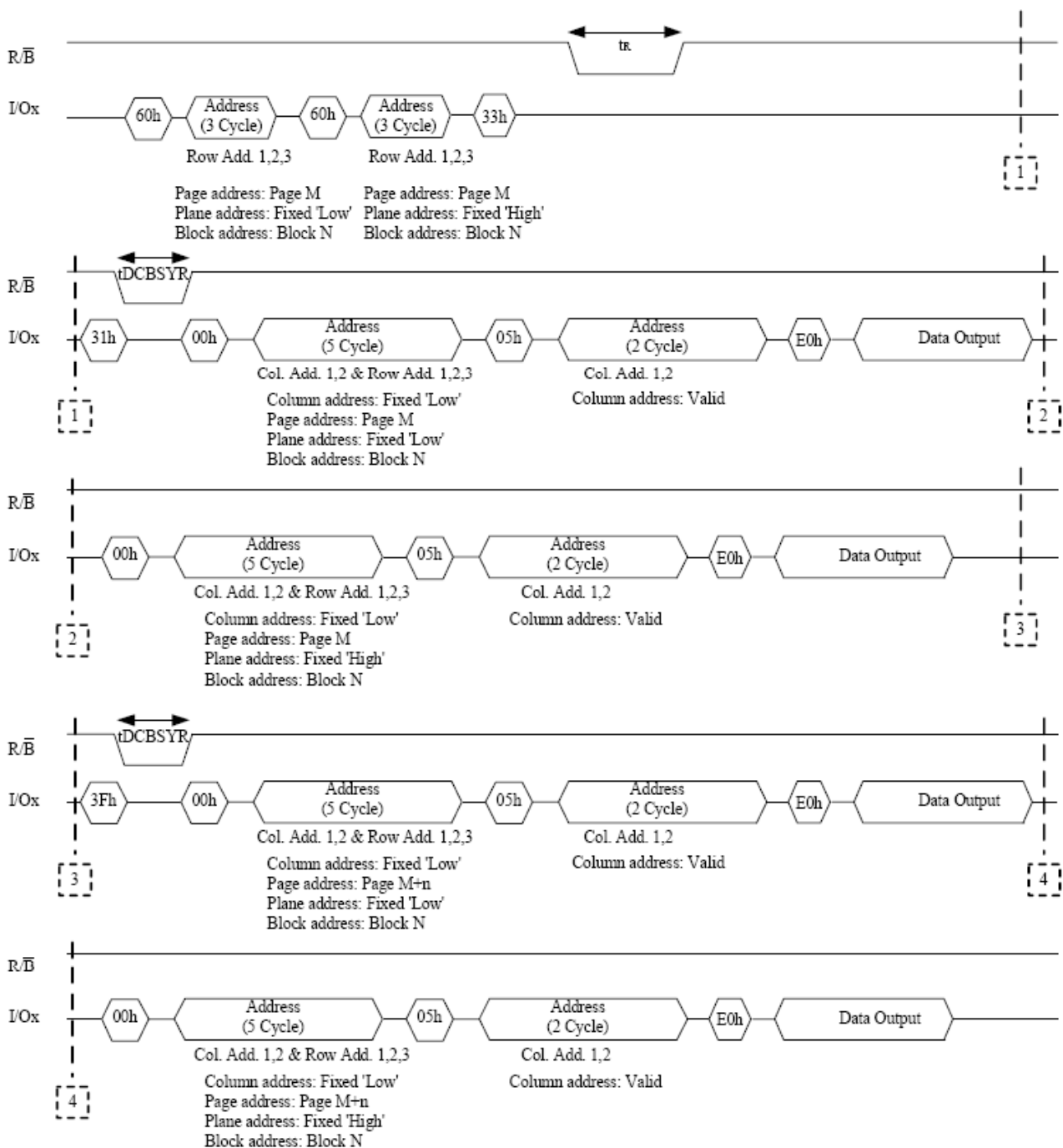

Two-Plane Page Program

Two-Plane Page Program is an extension of Page Program, for a single plane with 2,112 byte data registers. Since the device is equipped with two memory planes, activating the two sets of 2112 byte data registers enables a simultaneous programming of two pages.

After writing the first set of data up to 2,112 byte into the selected data registers via cache registers, Dummy Page Program command (11h) instead of actual Page Program command (10h) is inputted to finish data-loading of the first plane. Since no programming process is involved, R/B remains in busy state for a short period of time (t_{DBSY}). Read Status command (70h) may be issued to find out when the device returns to ready state by polling the R/B status bit (I/O 6). Then the next set of data for the other plane is inputted after 81h command and address sequences. After inputting data for the last page, actual True Page Program (10h) instead of dummy Page Program command (11h) must be followed to start the programming process. The operation of R/B and Read Status is the same as that of Page Program. Although two planes are programmed simultaneously, pass/fail is not available for each page when the program operation completes. Status bit of I/O 0 is set to "1" when any of the pages fails.

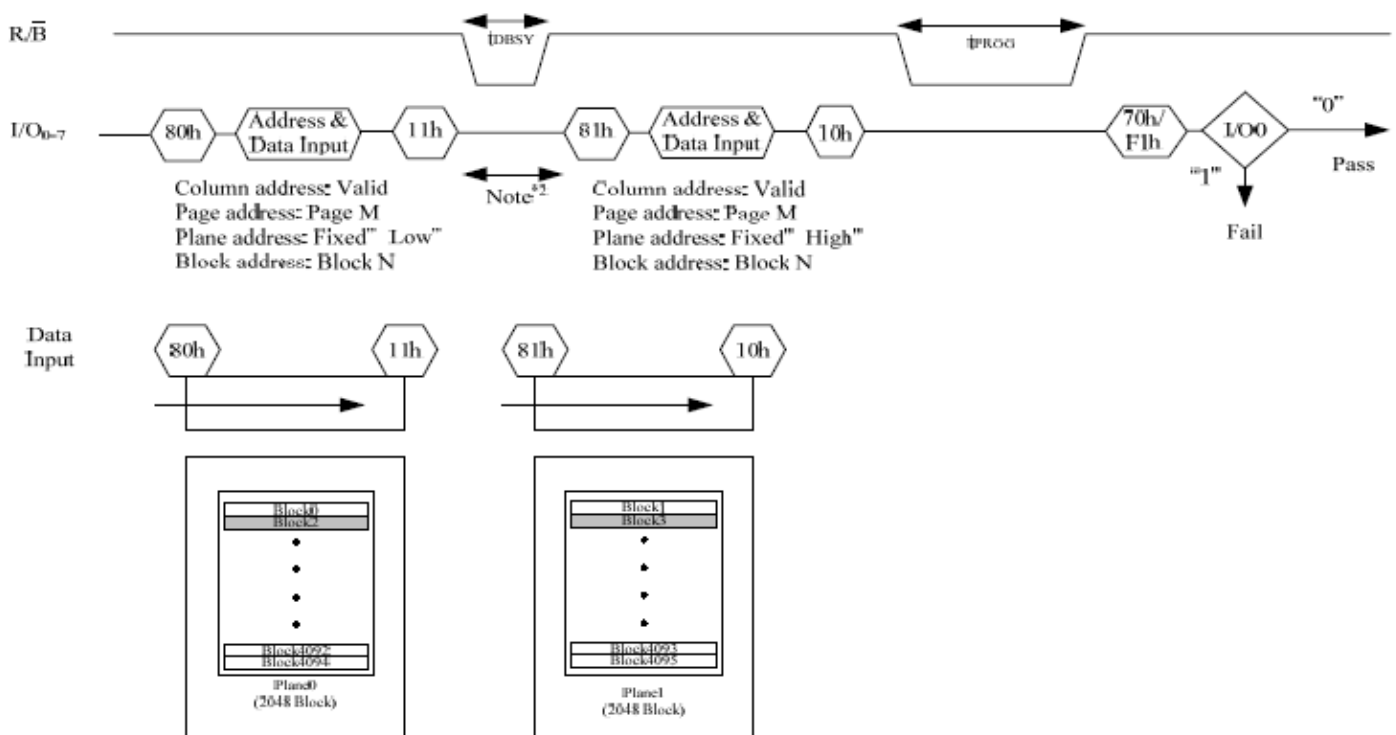

Two-Plane Copy-Back Program

Two-Plane Copy-Back Program is an extension of Copy-Back Program, for a single plane with 2,112 byte data registers. Since the device is equipped with two memory planes, activating the two sets of 2,112 byte data registers enables a simultaneous programming of two pages.

Two-Plane Copy-Back Program

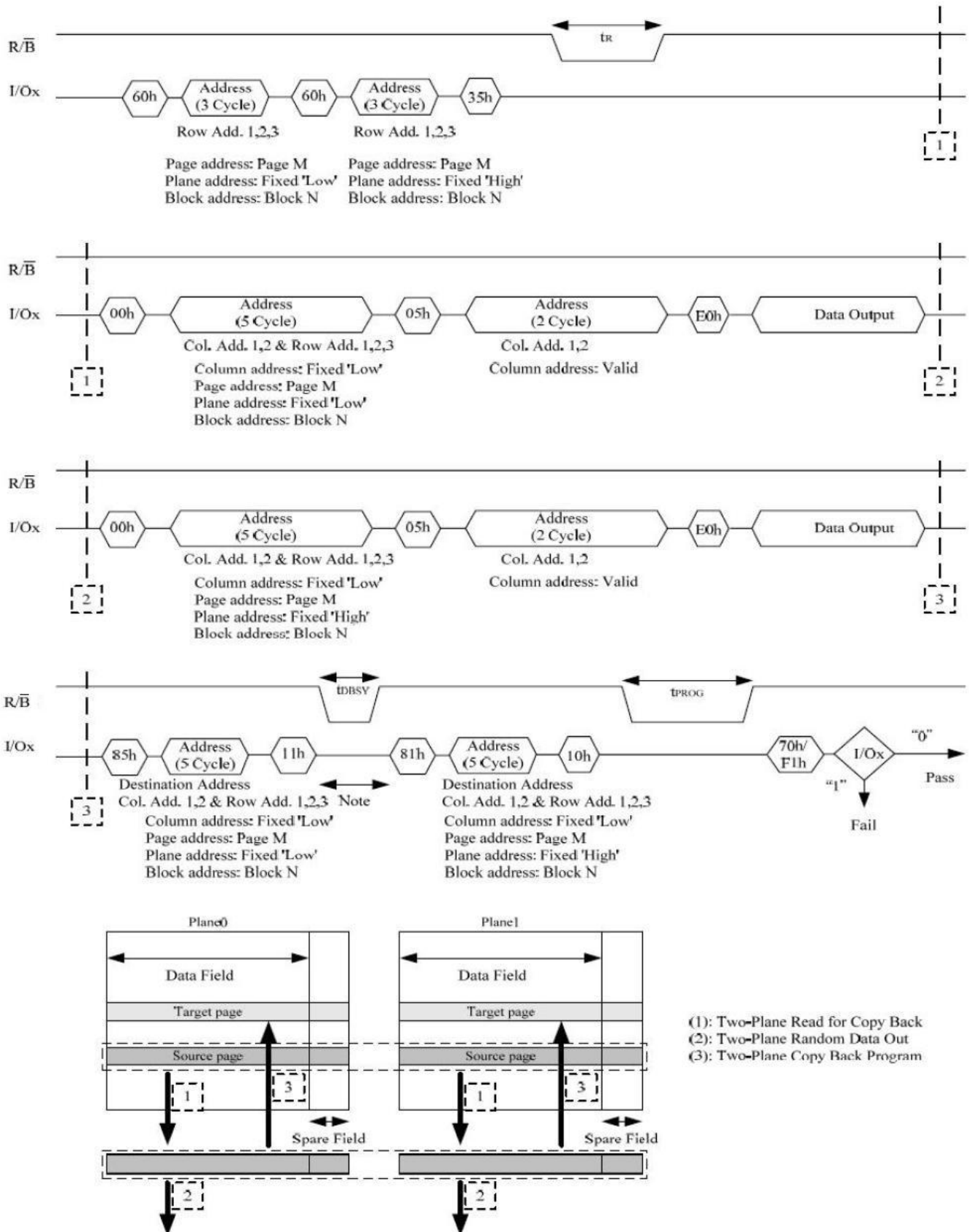

Two-Plane Copy-Back Program with Random Data Input

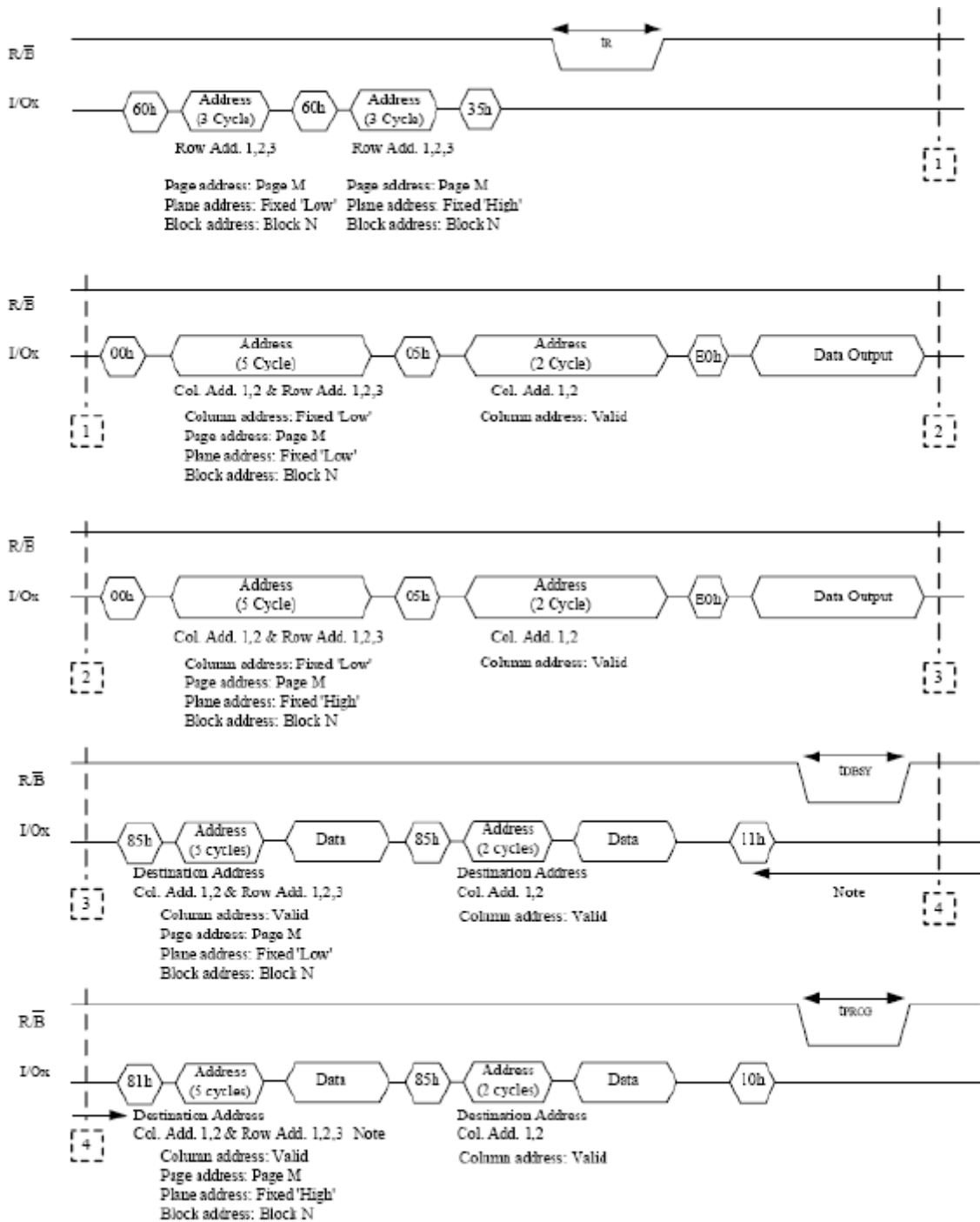

Two-Plane Cache Program

Two-Plane Cache Program is an extension of Cache Program, for a single plane with 2,112 byte data registers. Since the device is equipped with two memory planes, activating the two sets of 2,112 byte data registers enables a simultaneous programming of two pages.

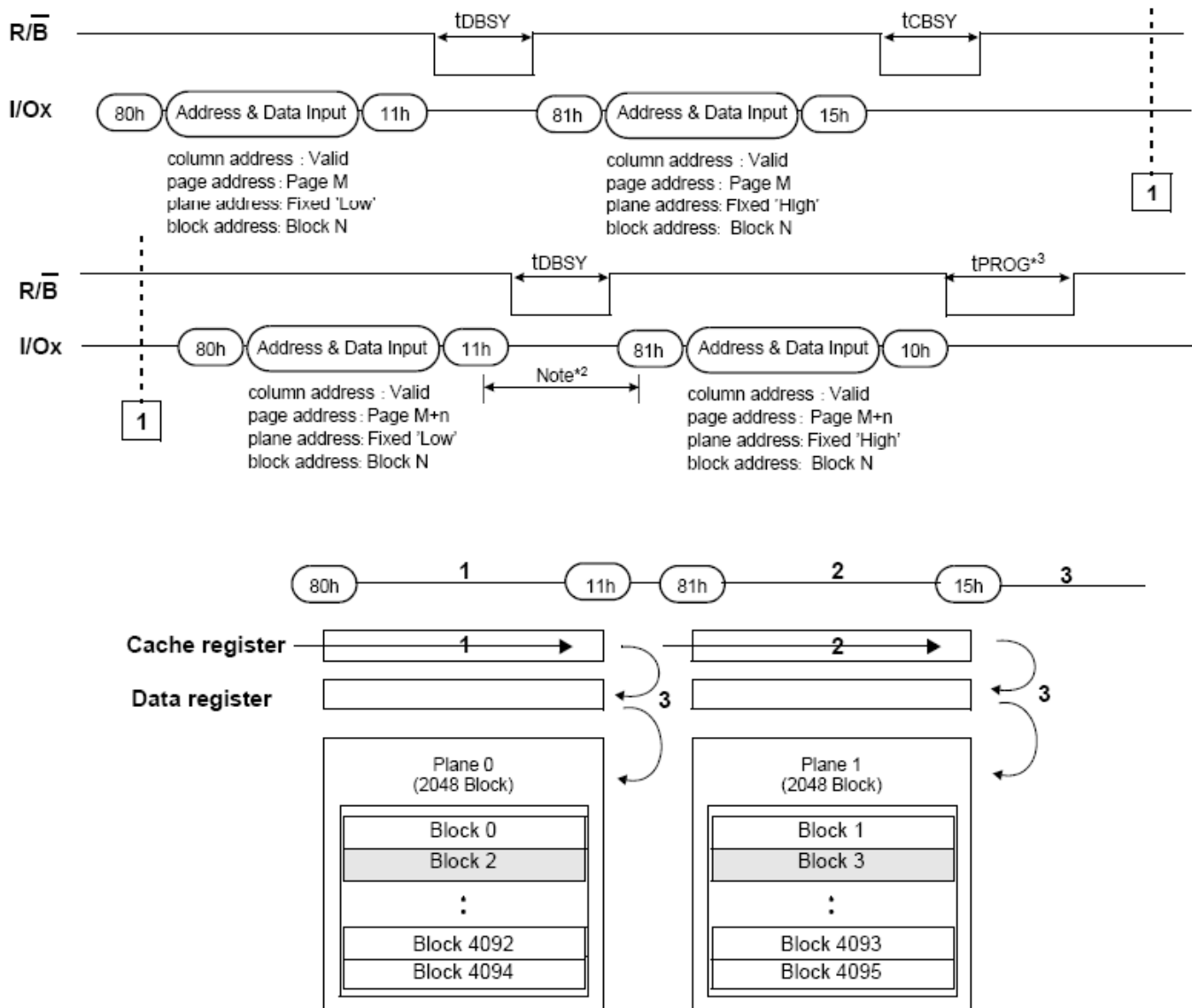

NOTE : 1. It is noticeable that same row address except for A_{20} is applied to the two blocks

2. Any command between 11h and 81h is prohibited except 70h/F1h and FFh.

3. Since programming the last page does not employ caching, the program time has to be that of Page Program. However, if the previous program cycle with the cache data has not finished, the actual program cycle of the last page is initiated only after completion of the previous cycle, which can be expressed as the following formula.

$$t_{PROG} = \text{Program time for the last page} + \text{Program time for the (last - 1)^{th} \text{ page}} \\ - (\text{Program command cycle time} + \text{Last page data loading time})$$

Two-Plane Block Erase

Basic concept of Two-Plane Block Erase operation is identical to that of Two-Plane Page Program. Up to two blocks, one from each plane can be simultaneously erased. Standard Block Erase command sequences (Block Erase Setup command 60h followed by three address cycles) may be repeated up to twice for erasing up to two blocks. Only one block should be selected from each plane. The Erase Confirm command (D0h) initiates the actual erasing process. The completion is detected by monitoring R/B pin or Ready/Busy status bit (I/O 6).

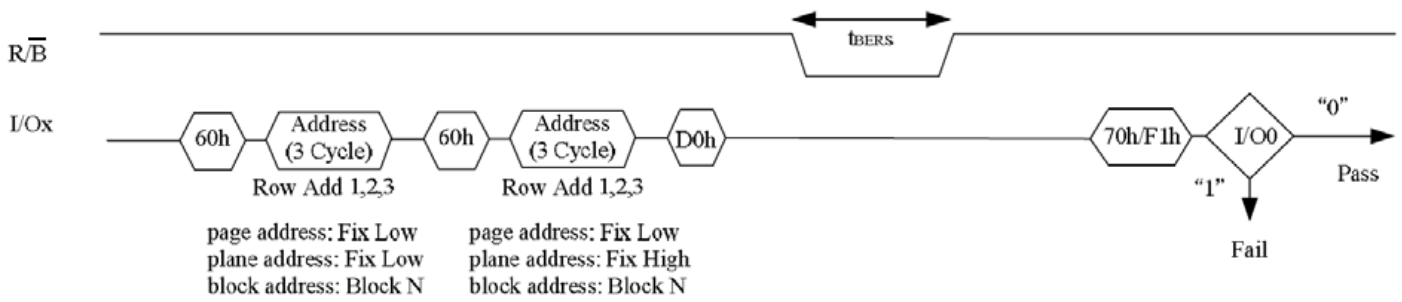

Ready / $\overline{\text{Busy}}$

The device has a $\overline{\text{R/B}}$ output that provides a hardware method of indicating the completion of a page program, erase and random read completion. The $\overline{\text{R/B}}$ pin is normally high but transition to low after program or erase command is written to the command register or random read is started after address loading. It returns to high when the internal controller has finished the operation. The pin is an open-drain driver thereby allowing two or more $\overline{\text{R/B}}$ outputs to be Or-tied. Because pull-up resistor value is related to t_r ($\overline{\text{R/B}}$) and current drain during busy (i_{busy}), an appropriate value can be obtained with the following reference chart (the following figure). Its value can be determined by the following guidance.

Read / $\overline{\text{Busy}}$ Pin Electrical Specifications

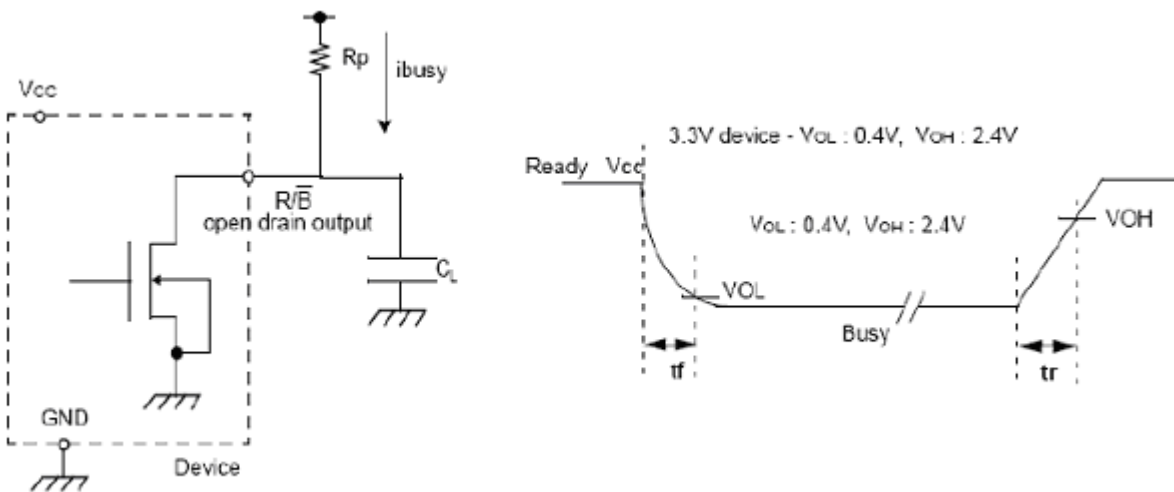

R_p VS t_{RHOH} VS C_L

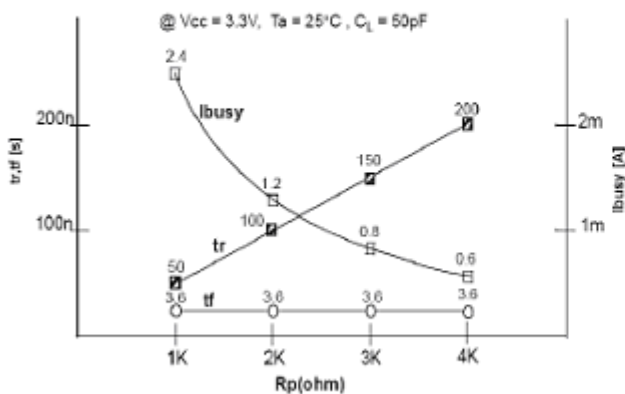

R_p value guidance

$$R_p(\text{min, 3.3V part}) = \frac{V_{CC}(\text{Max.}) - V_{OL}(\text{Max.})}{I_{OL} + \sum I_L} = \frac{3.2V}{8mA + \sum I_L}$$

where I_L is the sum of the input currents of all devices tied to the $\overline{\text{R/B}}\#$ pin.

R_p (max) is determined by maximum permissible limit of t_r

Data Protection & Power Up Sequence

The timing sequence shown in the following figure is necessary for the power-on/off sequence.

The device internal initialization starts after the power supply reaches an appropriate level in the power on sequence. During the initialization the device $\overline{R/\overline{B}}$ signal indicates the Busy state as shown in the following figure. In this time period, the acceptable commands are 70h.

The \overline{WP} signal is useful for protecting against data corruption at power on/off.

AC Waveforms for Power Transition

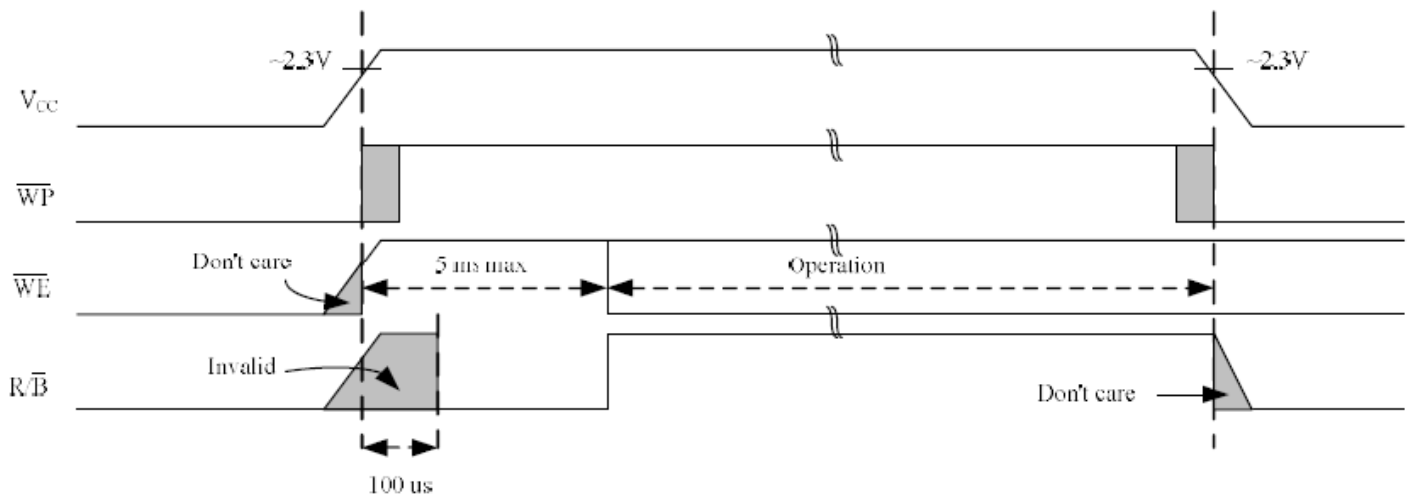

Write Protect Operation

Enabling \overline{WP} during erase and program busy is prohibited. The erase and program operations are enabled and disabled as follows:

Enable Programming

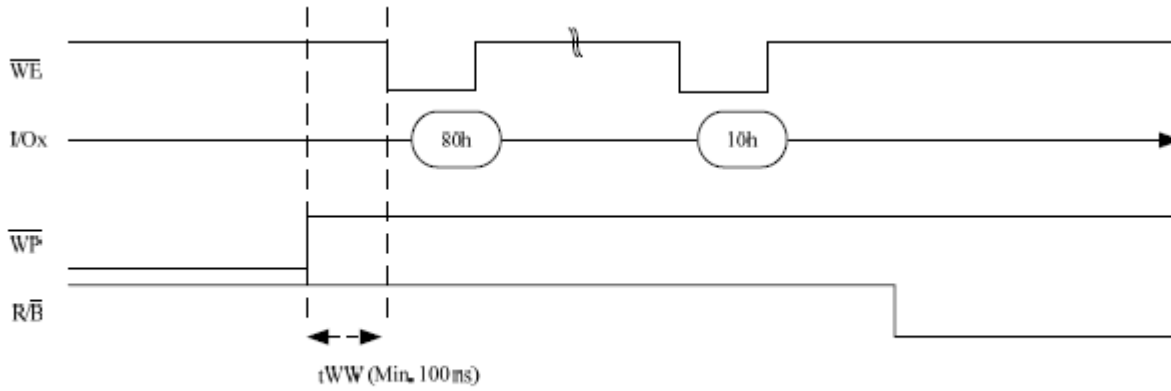

NOTE: \overline{WP} keeps "High" until programming finish

Disable Programming

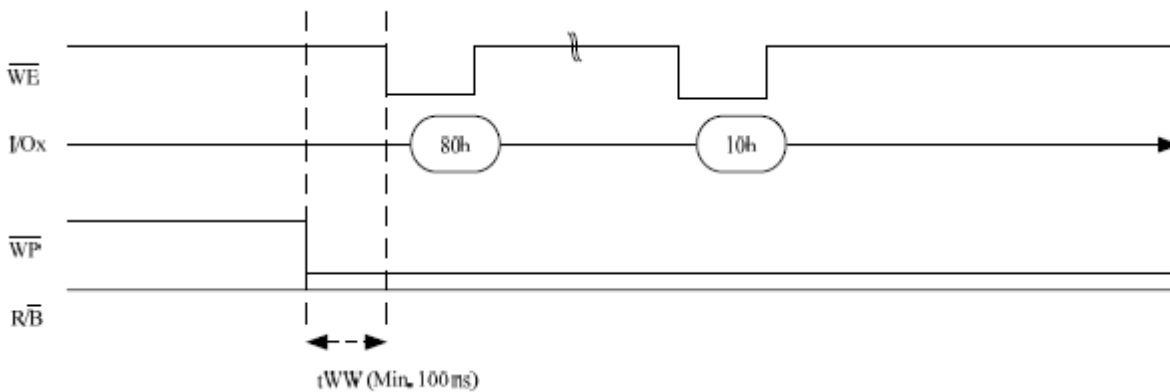

Enable Erasing

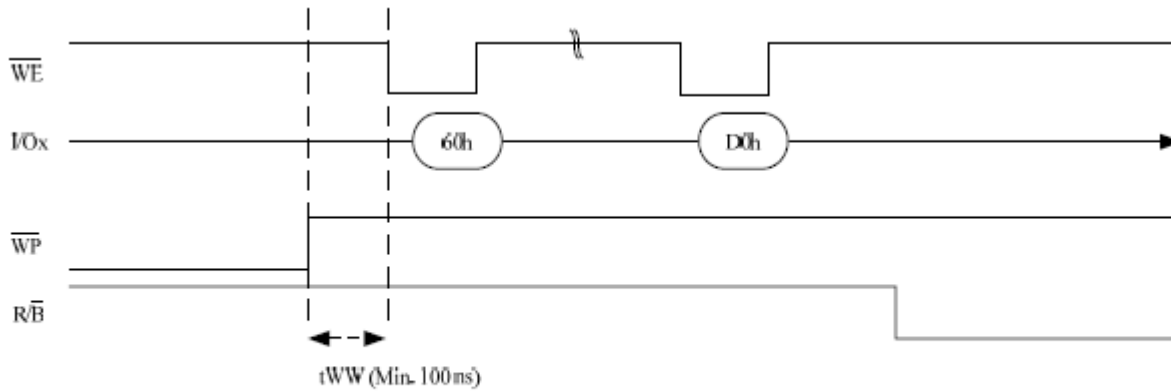

NOTE: \overline{WP} keeps "High" until erasing finish

Disable Erasing

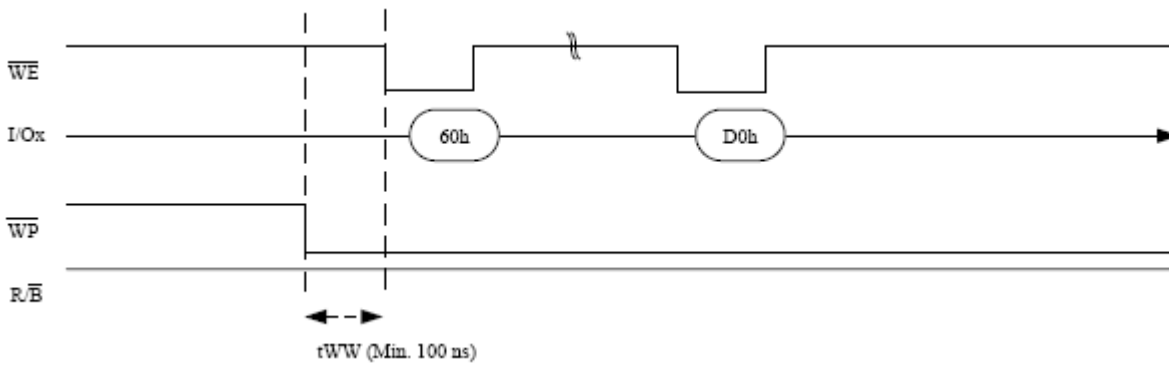

PACKING DIMENSION

48-LEAD TSOP(I) (12x20 mm)

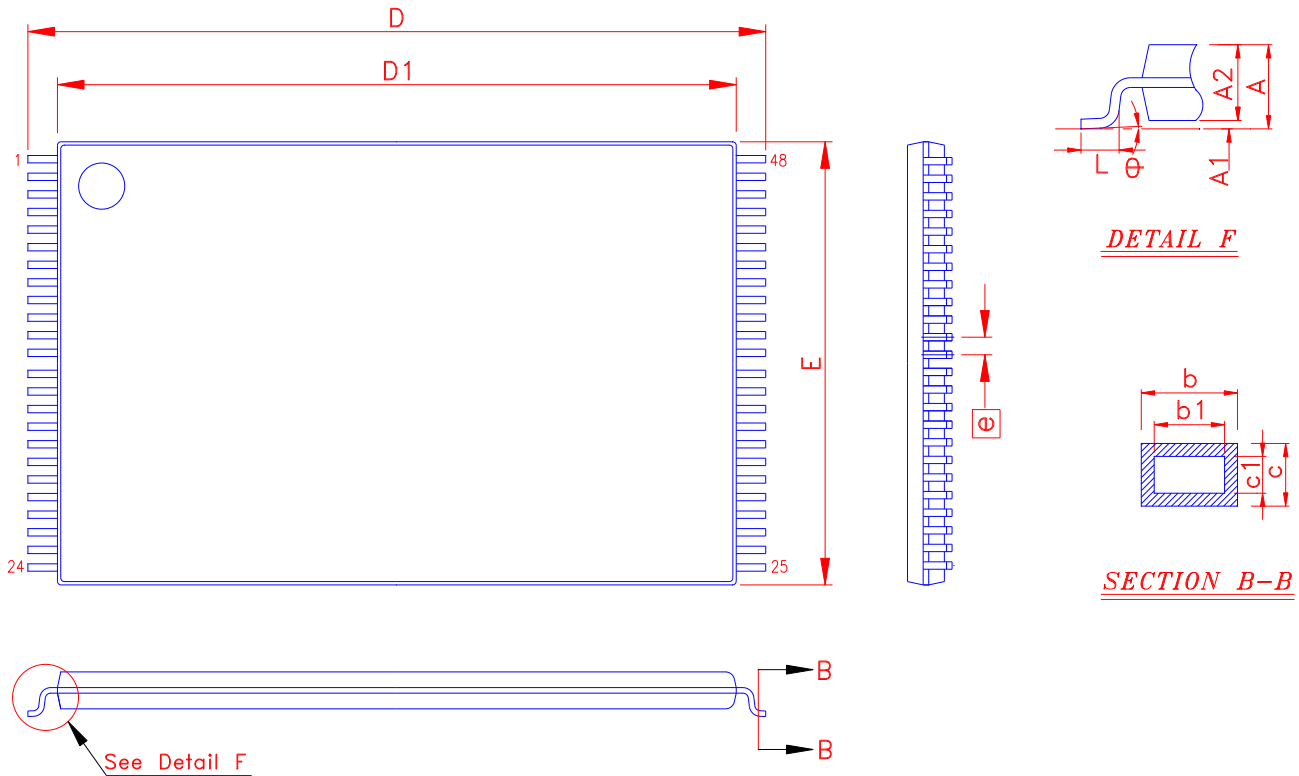

Symbol	Dimension in mm			Dimension in inch			Symbol	Dimension in mm			Dimension in inch		
	Min	Norm	Max	Min	Norm	Max		Min	Norm	Max	Min	Norm	Max
A	-----	-----	1.20	-----	-----	0.047	D	20.00	BSC		0.787	BSC	
A 1	0.05	-----	0.15	0.006	-----	0.002	D 1	18.40	BSC		0.724	BSC	
A 2	0.95	1.00	1.05	0.037	0.039	0.041	E	12.00	BSC		0.472	BSC	
b	0.17	0.22	0.27	0.007	0.009	0.011	e	0.50	BSC		0.020	BSC	
b1	0.17	0.20	0.23	0.007	0.008	0.009	L	0.50	0.60	0.70	0.020	0.024	0.028
c	0.10	-----	0.21	0.004	-----	0.008	theta	0°	-----	8°	0°	-----	8°
c1	0.10	-----	0.16	0.004	-----	0.006							

Revision History

Revision	Date	Description
1.0	2018.11.05	Original

Important Notice

All rights reserved.

No part of this document may be reproduced or duplicated in any form or by any means without the prior permission of ESMT.

The contents contained in this document are believed to be accurate at the time of publication. ESMT assumes no responsibility for any error in this document, and reserves the right to change the products or specification in this document without notice.

The information contained herein is presented only as a guide or examples for the application of our products. No responsibility is assumed by ESMT for any infringement of patents, copyrights, or other intellectual property rights of third parties which may result from its use. No license, either express, implied or otherwise, is granted under any patents, copyrights or other intellectual property rights of ESMT or others.

Any semiconductor devices may have inherently a certain rate of failure. To minimize risks associated with customer's application, adequate design and operating safeguards against injury, damage, or loss from such failure, should be provided by the customer when making application designs.

ESMT's products are not authorized for use in critical applications such as, but not limited to, life support devices or system, where failure or abnormal operation may directly affect human lives or cause physical injury or property damage. If products described here are to be used for such kinds of application, purchaser must do its own quality assurance testing appropriate to such applications.